

**GB** **Light oil burner**  
**CN** **轻油燃烧器**

Two-stage operation  
两段火运行



CODE- 编码	MODEL- 型号	TYPE- 类型
20042311	RL 70	660 T1
20042308	RL 100	661 T1
20042309	RL 130	662 T1



<b>1</b>	<b>Declarations</b>	<b>2</b>
<b>2</b>	<b>Information and general instructions</b>	<b>3</b>
2.1	Information about the instruction manual	3
2.2	Guarantee and responsibility	4
<b>3</b>	<b>Safety and prevention</b>	<b>5</b>
3.1	Introduction	5
3.2	Personnel training	5
<b>4</b>	<b>Technical description of the burner</b>	<b>6</b>
4.1	Technical data	6
4.2	Burner description (Fig. 1)	7
4.3	Firing rates (Fig. 3)	9
<b>5</b>	<b>Installation</b>	<b>10</b>
5.1	Handling	10
5.2	Preliminary checks	10
5.3	Boiler plate (Fig. 6)	11
5.4	Blast tube length (Fig. 7)	11
5.5	Securing the burner to the boiler (Fig. 8)	11
5.6	Choice of nozzles for 1st and 2nd stage	12
5.7	Nozzle assembly	13
5.8	Combustion head setting	14
<b>6</b>	<b>Electrical system</b>	<b>15</b>
6.1	Electrical system (factory set)	16
<b>7</b>	<b>Hydraulic system</b>	<b>18</b>
7.1	Fuel supply	18
7.2	Hydraulic connections (Fig. 20)	19
7.3	Pump (Fig. 21)	19
<b>8</b>	<b>Burner calibration</b>	<b>20</b>
8.1	Firing	20
8.2	Operation	20
<b>9</b>	<b>Maintenance</b>	<b>23</b>
9.1	Burner start-up cycle diagnostics	25
9.2	Resetting the control box and using diagnostics	25
9.3	Resetting the control box	25
9.4	Visual diagnostics	25
9.5	Software diagnostics	26
<b>10</b>	<b>STATUS (optional)</b>	<b>28</b>
10.1	Assembly	28
10.2	The STATUS unit has three functions:	28

**1 Declarations**

**Declaration of conformity in accordance with ISO / IEC 17050-1**

Manufacturer:	RIELLO S.p.A.		
Address:	Via Pilade Riello, 7 37045 Legnago (VR)		
Product:	Light oil burners		
Model:	RL 70 RL 100 RL 130		
These products are in compliance with the following Technical Standards:			
EN 267			
EN 12100			
and according to the European Directives:			
MD	2006/42/EC	Machine Directive	
LVD	2006/95/EC	Low Voltage Directive	
EMC	2004/108/EC	Electromagnetic Compatibility	

The quality is guaranteed by a quality and management system certified in accordance with UNI EN ISO 9001.

**Manufacturer's Declaration**

**RIELLO S.p.A.** declares that the following products comply with the NOx emission limits specified by German standard "1. BImSchV release 26.01.2010".

Product	Type	Model	Power
Light oil burner	661 T1	RL 100	356 - 1186 kW
	662 T1	RL 130	486 - 1540 kW

Legnago, 15.03.2010

Mr. G. Conticini  
Burners Division Department  
RIELLO S.p.A.



## 2 Information and general instructions

### 2.1 Information about the instruction manual

#### Introduction

The instruction manual supplied with the burner:

- is an integral and essential part of the product and must not be separated from it; it must therefore be kept carefully for any necessary consultation and must accompany the burner even if it is transferred to another owner or user, or to another system. If the manual is lost or damaged, another copy must be requested from the Technical Assistance Service **RIELLO** of the area;
- is designed for use by qualified personnel;
- offers important indications and instructions relating to the installation safety, start-up, use and maintenance of the burner.

#### Symbols used in the manual

In some parts of the manual you will see triangular DANGER signs. Pay great attention to these, as they indicate a situation of potential danger.

#### 2.1.1 General dangers

The **dangers** can be of **3 levels**, as indicated below.



Maximum danger level!

This symbol indicates operations which, if not carried out correctly, **cause** serious injury, death or long-term health risks.



This symbol indicates operations which, if not carried out correctly, **may cause** serious injury, death or long-term health risks.



This symbol indicates operations which, if not carried out correctly, **may cause** damage to the machine and/or injury to people.

#### 2.1.2 Danger: live components



This symbol indicates operations which, if not carried out correctly, lead to electric shocks with lethal consequences.

Other symbols



#### ENVIRONMENTAL PROTECTION

This symbol gives indications for the use of the machine with respect for the environment.

- This symbol indicates a list.

#### Abbreviations used

Ch.	Chapter
Fig.	Figure
Pag.	Page
Sec.	Section
Tab.	Table

#### Delivery of the system and the instruction manual

When the system is delivered, it is important that:

- The instruction manual is supplied to the user by the system manufacturer, with the recommendation to keep it in the room where the heat generator is to be installed.
- The instruction manual shows:
  - the serial number of the burner;
  - the address and telephone number of the nearest Assistance Centre;
- The system supplier carefully informs the user about:
  - the use of the system,
  - any further tests that may be necessary before the system is started up,
  - maintenance and the need to have the system checked at least once a year by the manufacturer or another specialised technician.

To ensure a periodic check, **RIELLO** recommends the drawing up of a Maintenance Contract.

## 2.2 Guarantee and responsibility

**RIELLO** guarantees its new products from the installation date, in accordance with the regulations in force and/or the sales contract. At the moment of the first start-up, check that the burner is integral and complete.



**WARNING**

Failure to observe the information given in this manual, operating negligence, incorrect installation and the carrying out of non authorised modifications will result in the annulment by **RIELLO** of the guarantee that it supplies with the burner.

In particular, the rights to the guarantee and the responsibility will no longer be valid, in the event of damage to things or injury to people, if such damage/injury was due to any of the following causes:

- incorrect installation, start-up, use and maintenance of the burner;
- improper, incorrect or unreasonable use of the burner;
- intervention of unqualified personnel;
- carrying out of non authorised modifications on the equipment;
- use of the burner with safety devices that are faulty, incorrectly applied and/or not working;
- installation of untested supplementary components on the burner;
- powering of the burner with unsuitable fuels;
- faults in the fuel power supply system;
- use of the burner even following an error and/or an irregularity;
- repairs and/or overhauls incorrectly carried out;
- modification of the combustion chamber with inserts that prevent the regular development of the flame, as structurally established;
- insufficient and inappropriate surveillance and care of those burner components most subject to wear and tear;
- use of non-original **RIELLO** components, including spare parts, kits, accessories and optionals;
- force majeure.

**RIELLO** furthermore declines any and every responsibility for the failure to observe the contents of this manual.

## 3 Safety and prevention

### 3.1 Introduction

The **RIELLO** burners have been designed and built in compliance with current regulations and directives, applying the known technical rules of safety and envisaging all the potential danger situations.

It is necessary, however, to bear in mind that the imprudent and clumsy use of the equipment may lead to situations of death risk for the user or third parties, as well as the damaging of the burner or other items. Inattention, thoughtlessness and excessive confidence often cause accidents; the same applies to tiredness and sleepiness.

It is a good idea to remember the following:

- The burner must only be used as expressly described. Any other use should be considered improper and therefore dangerous.  
In particular:  
it can be applied to boilers operating with water, steam, diathermic oil, and to other users expressly named by the manufacturer;  
the type and pressure of the fuel, the voltage and frequency of the electrical power supply, the minimum and maximum deliveries for which the burner has been regulated, the pressurisation of the combustion chamber, the dimensions of the combustion chamber and the room temperature must all be within the values indicated in the instruction manual.
- Modification of the burner to alter its performance and destinations is not allowed.
- The burner must be used in exemplary technical safety conditions. Any disturbances that could compromise safety must be quickly eliminated.
- Opening or tampering with the burner components is not allowed, apart from the parts requiring maintenance.
- Only those parts envisaged by the manufacturer can be replaced.

### 3.2 Personnel training

The user is the person, body or company that has acquired the machine and intends to use it for the specific purpose. He is responsible for the machine and for the training of the people working around it.

The user:

- undertakes to entrust the machine exclusively to suitably trained and qualified personnel;
- must take all the measures necessary to prevent unauthorised people gaining access to the machine;
- undertakes to inform his personnel in a suitable way about the application and observance of the safety instructions. With that aim, he undertakes to ensure that everyone knows the use and safety instructions for his own duties;
- must inform the manufacturer if faults or malfunctioning of the accident prevention systems are noticed, along with any presumed danger situation.
- Personnel must always use the personal protective equipment envisaged by legislation and follow the indications given in this manual.
- Personnel must follow all the danger and caution indications shown on the machine.
- Personnel must not carry out, on their own initiative, operations or interventions that are not within their province.
- Personnel are obliged to inform their superiors of every problem or dangerous situation that may arise.
- The assembly of parts of other makes, or any modifications, can alter the characteristics of the machine and hence compromise operating safety. The manufacturer therefore declines any and all responsibility for any damage that may be caused by the use of non-original parts.

### 4 Technical description of the burner

#### 4.1 Technical data

MODEL			RL 70	RL 100	RL 130
TYPE			660 T1	661 T1	662 T1
OUTPUT <sup>(1)</sup> DELIVERY <sup>(1)</sup>	2nd stage	kW	474 - 830	711 - 1186	948 - 1540
		Mcal/h	408 - 714	612 - 1020	816 - 1325
		kg/h	40 - 70	60 - 100	80 - 130
	1nd stage	kW	255 - 474	356 - 711	486 - 948
		Mcal/h	219 - 408	306 - 612	418 - 816
		kg/h	21.5 - 40	30 - 60	41 - 80
FUEL			LIGHT OIL		
- Net calorific value		kWh/kg Mcal/kg	11.8 10.2 (10.200 Kcal/kg)		
- Density		kg/dm <sup>3</sup>	0.82 - 0.85		
- viscosity at 20 °C		mm <sup>2</sup> /s max	6 (1,5 °E - 6 cSt)		
OPERATION			Intermittent (min. 1 stop in 24 hours). Two-stage (high and low flame) and single-stage (all - nothing).		
NOZZLES		number	2		
STANDARD APPLICATIONS			Boilers: water, steam, diathermic oil		
AMBIENT TEMPERATURE		°C	0 - 40		
COMBUSTION AIR TEMPERATURE		°C max	60		
POWER SUPPLY		V Hz	230 - 400 with neutral ~ +/- 10% 50 - three-phase		
ELECTRICAL MOTOR		rpm W V A	2800 1100 220/240 - 380/415 4.7 - 2.7	2800 1500 220/240 - 380/415 6.4 - 3.7	2800 2200 220/240 - 380/415 8.5 - 4.9
IGNITION TRASFORMER		V1 - V2 I1 - I2	230 V - 2 x 5 kV 1.9 A - 30 mA		
PUMP	delivery (at 12 bar)	kg/h	107	220	220
	pressure range	bar	10 - 20	10 - 20	10 - 20
	fuel temperature	°C max	60	60	60
ELECTRICAL POWER CONSUMPTION		W max	1400	1800	2600
ELECTRICAL PROTECTION			IP 44		
IN CONFORMITY WITH EEC DIRECTIVES			2004/108 - 2006/95 - 2006/42		
NOISE LEVELS <sup>(2)</sup>		dBA	75	77	78.5

(1) Reference conditions: Ambient temperature 20 °C - Barometric pressure 1000 mbar - Altitude 100 m a.s.l.

(2) Sound pressure measured in manufacturer's combustion laboratory, with burner operating on test boiler and at maximum rated output.

#### 4.1.1 Variants

Model	Code	Power supply electrical	Length of blast tube mm
RL 70	20042311	Three-phase	250
RL 100	20042308	Three-phase	250
RL 130	20042309	Three-phase	250

#### • RADIO DISTURBANCE PROTECTION KIT

If the burner is installed in places particularly subject to radio disturbance (emission of signals exceeding 10 V/m) owing to the presence of an INVERTER, or in applications where the length of the thermostat connections exceeds 20 metres, a protection kit is available as an interface between the control box and the burner.

BURNER	RL 70 - RL 100 - RL 130
Code	3010386

#### 4.1.2 Accessories (optional):

- **STATUS** (see pag. 28): code 3010322



**• DEGASSING UNIT**

It may occur that a certain amount of air is contained in the light oil sucked up by the pump. This air may originate from the light oil itself as a consequence of depressurization or air leaking past imperfect seals.

In double-pipe systems, the air returns to the tank from the return pipe; in single-pipe systems, the air remains in circulation causing pressure variations in the pump and burner malfunctions.

For this reason, we advise installing a degassing unit near the burner in single-pipe installations.

Degassing units are provided in two versions:

CODE **3010054** without filter

CODE **3010055** with filter

- Burner delivery : max. 80 kg/h
- Light oil pressure : max. 0.7 bar
- Ambient temperature : max. 50 °C (without filter)
- Ambient temperature : max. 40 °C (with filter)
- Light oil temperature : max. 50 °C (without filter)
- Light oil temperature : max. 40 °C (with filter)
- Connectors : 1/4 inch

For burner deliveries higher than 80 kg/h, install two parallel degassing units

**4.2 Burner description (Fig. 1)**

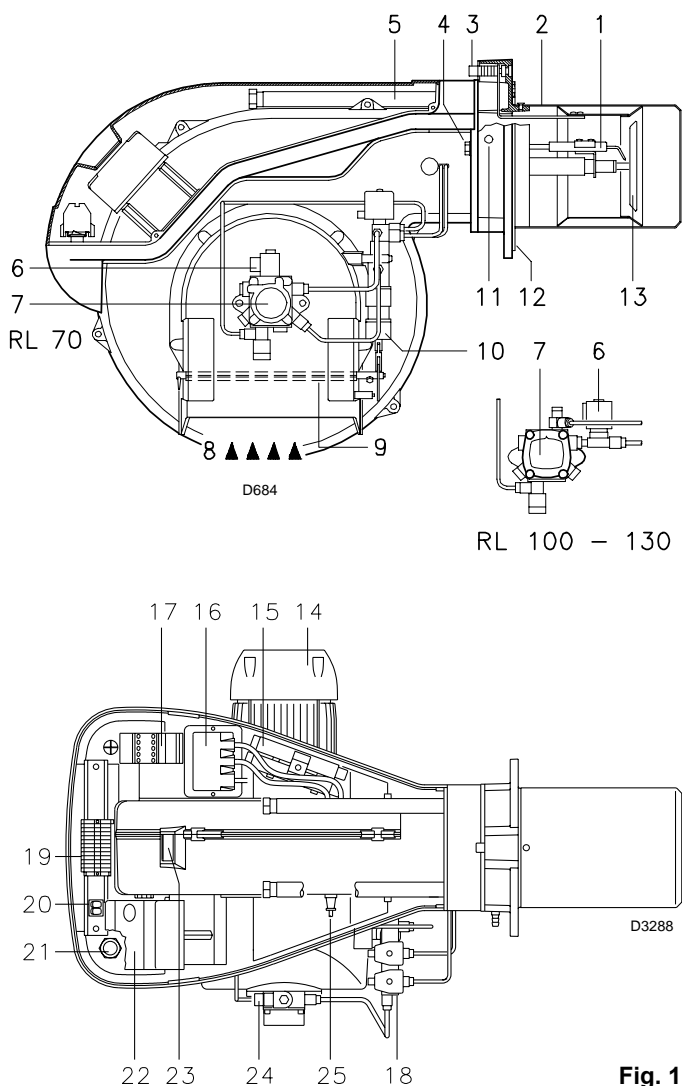

- 1 Ignition electrodes
- 2 Combustion head
- 3 Screw for combustion head adjustment
- 4 Screw for fixing fan to flange
- 5 Slide bars for opening the burner and inspecting the combustion head
- 6 Safety solenoid valve
- 7 Pump
- 8 Air inlet to fan
- 9 Air gate valve
- 10 Hydraulic cylinder for regulation of the air gate valve in 1st and 2nd stage positions.  
When the burner is not operating the air gate valve is fully closed in order to reduce heat dispersion from the boiler due to the flue draught which draws air from the fan suction inlet.
- 11 Fan pressure test point
- 12 Boiler mounting flange
- 13 Flame stability disk
- 14 Electrical motor
- 15 Extensions for slide bars 5)
- 16 Ignition transformer
- 17 Motor contactor and thermal cut-out with reset button
- 18 1st and 2nd stage valve assembly
- 19 Terminal strip
- 20 Two switches:  
- one "burner off - on"  
- one for "1st - 2nd stage operation"
- 21 Fairleads for wiring carried out by the installer
- 22 Control box with lock-out pilot light and lock-out reset button
- 23 Flame inspection window
- 24 Pump pressure adjustment
- 25 Photoresistor for flame presence control

Two types of burner failure may occur:

**Control box lock-out:** if the control box 22)(Fig. 1) pushbutton (red led) lights up, it indicates that the burner is in lock-out.

To reset, hold the pushbutton down for between 1 and 3 seconds.

**Motor trip:** release by pressing the pushbutton on thermal cut-out 17)(Fig. 1).

**Fig. 1**

	kg
RL 70	60
RL 100	63
RL 130	66

**Tab. A**

**4.2.1 Weight (Tab. A) - approximate measurements**

- The weight of the burner complete with its packaging is shown in table (Tab. A)

**4.2.2 Max. dimensions (Fig. 2) - approximate measurements**

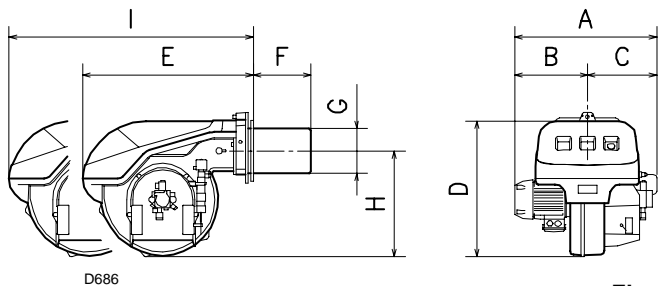

**Fig. 2**

The maximum dimensions of the burner are given in (Fig. 2).

Bear in mind that inspection of the combustion head requires the burner to be opened and the rear part withdrawn on the slide bars.

The dimensions of the open burner are indicated by position I.

mm	A	B	C	D	E	F	G	H	I
RL 70	580	296	284	555	680	250	179	430	951
RL 100	599	312	287	555	680	250	179	430	951
RL 130	625	338	287	555	680	250	189	430	951

**4.2.3 Standard equipment**

- 2 - Flexible hoses
- 2 - Gaskets for flexible hoses
- 2 - Nipples for flexible hoses
- 1 - Thermal insulation screen
- 2 Extensions 15)(Fig. 1) for slide bars 5)(Fig. 1)  
(for models with 385 mm blast tube)
- 4 - Screws to secure the burner flange to the boiler: M 12 x 35
- 2 - Nozzles
- 1 - Instruction booklet
- 1 - Spare parts list

**4.3 Firing rates (Fig. 3)**

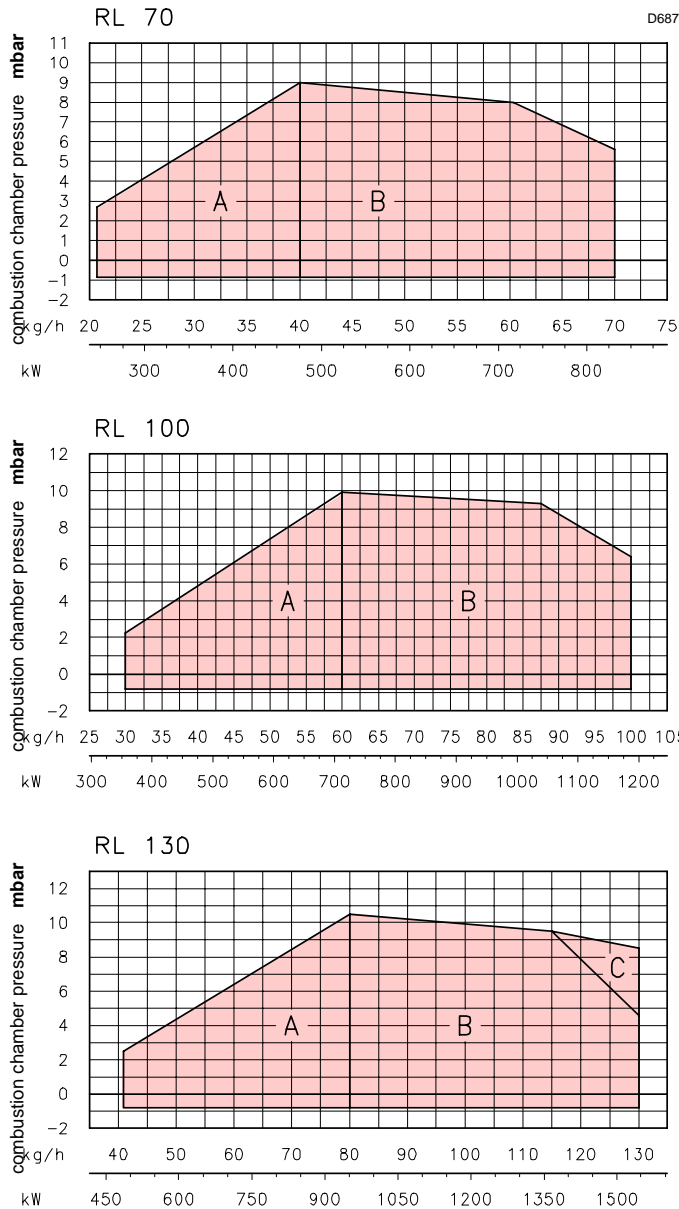

The RL 70 - 100 - 130 burners model can work in two ways: one-stage and two-stage.

**1st stage DELIVERY** must be selected within area A of the adjacent diagrams.

**2nd stage DELIVERY** must be selected within area B (and C for model RL 130). This area provides the maximum delivery of the burner in relation to the pressure in the combustion chamber.

The work point may be found by plotting a vertical line from the desired delivery and a horizontal line from the pressure in the combustion chamber. The intersection of these two lines is the work point which must lie within area B.

In order to utilize also area C (RL 130) it is necessary to perform the calibration of the combustion head as explained on pag. 11.



The FIRING RATE area values have been obtained considering a surrounding temperature of 20 °C, and an atmospheric pressure of 1000 mbar (approx. 100 m above sea level) and with the combustion head adjusted as shown on pag. 14.

**4.3.1 Test boiler (Fig. 4)**

The firing rates were set in relation to special test boilers in accordance with the methods defined in EN 267 standards.

Fig. 4 indicates the diameter and length of the test combustion chamber.

**Example:**

delivery 65 kg/hour:

diameter = 60 cm; length = 2 m.

Whenever the burner is operated in a much smaller commercially-available combustion chamber, a preliminary test should be performed.

**Fig. 3**

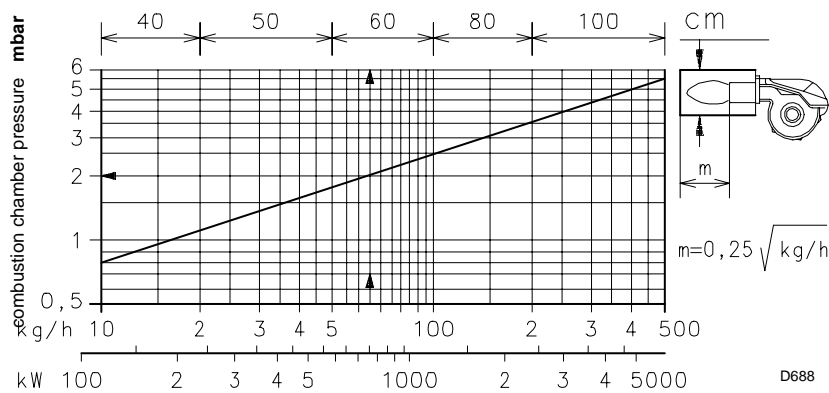

**Fig. 4**

**5 Installation**

**Notes on safety for the installation**

After carefully cleaning all around the area where the burner will be installed, and arranging the correct lighting of the environment, proceed with the installation operations.



All the installation, maintenance and disassembly operations must be carried out with the electricity supply disconnected.



The installation of the burner must be carried out by qualified personnel, as indicated in this manual and in compliance with the standards and regulations of the laws in force.

**5.1 Handling**

The packaging of the burner includes a wooden platform, so it is possible to move the burner (still packaged) with a transpallet truck or fork lift truck.



**WARNING**

The handling operations for the burner can be highly dangerous if not carried out with the greatest attention: keep any unauthorised people at a distance; check the integrity and suitability of the available means of handling. Check also that the area in which you are working is empty and that there is an adequate escape area (i.e. a free, safe area to which you can quickly move if the burner should fall). During the handling, keep the load at not more than 20-25 cm from the ground.



**CAUTION**

After positioning the burner near the installation point, correctly dispose of all residual packaging, separating the various types of material. Before proceeding with the installation operations, carefully clean all around the area where the burner will be installed.

**5.2 Preliminary checks**

**Checking the consignment**





**CAUTION**

After removing all the packaging, check the integrity of the contents. In the event of doubt, do not use the burner; contact the supplier.



The packaging elements (wooden cage or cardboard box, nails, clips, plastic bags, etc.) must not be abandoned as they are potential sources of danger and pollution; they should be collected and disposed of in the appropriate places.

**Checking the characteristics of the burner**

<b>R.B.L.</b>	<b>A</b>			<b>G</b>
	<b>B</b>	<b>C</b>		
	<b>D</b>	<b>E</b>		
	<b>F</b>			
RIELLO Sp.A I-37045 Legnago (VR)				
				
 0036				

D8965

**Fig. 5**

- the data of the burner's minimum and maximum output possibilities (**G**) (see Firing rate)



**WARNING**

The output of the burner must be within the boiler's firing rate;



**WARNING**

A burner label that has been tampered with, removed or is missing, along with anything else that prevents the definite identification of the burner makes any installation or maintenance work difficult.

- Check the identification label of the burner, showing:
- the model (see **A** in Fig. 5) and type of burner (**B**);
  - the year of manufacture, in cryptographic form (**C**);
  - the serial number (**D**);
  - the electrical input power (**E**);
  - the types of fuel used and the relative supply pressures (**F**);

**5.3 Boiler plate (Fig. 6)**

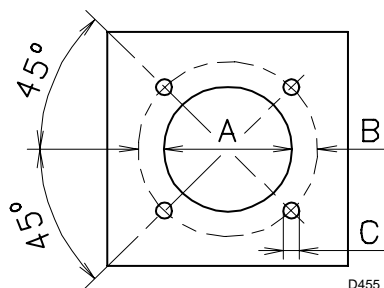

Fig. 6

Drill the combustion chamber locking plate as shown in (Fig. 6). The position of the threaded holes can be marked using the thermal screen supplied with the burner.

mm	A	B	C
RL 70	185	275-325	M 12
RL 100	185	275-325	M 12
RL 130	195	275-325	M 12

**5.4 Blast tube length (Fig. 7)**

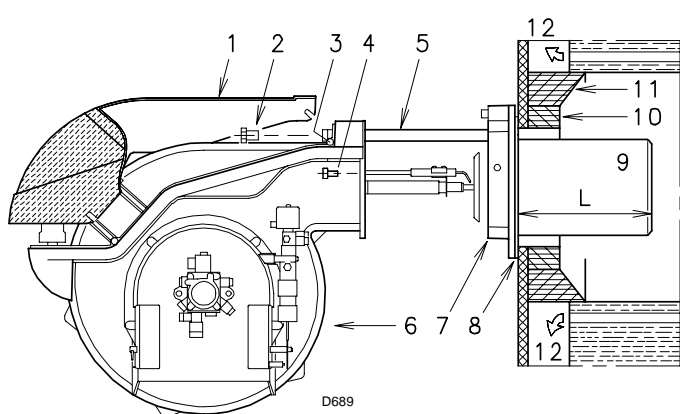

Fig. 7

The length of the blast tube must be selected according to the indications provided by the manufacturer of the boiler, and in any case it must be greater than the thickness of the boiler door complete with its fettling.

Blast tube 9):	RL 70	RL 100	RL 130
L = mm	250	250	250

For boilers with front flue passes 12) or flame inversion chambers, protective fettling in refractory material 10) must be inserted between the boiler's fettling 11) and the blast tube 9).

This protective fettling must not compromise the extraction of the blast tube.

For boilers having a water-cooled front the refractory fettling 10)-11)(Fig. 7) is not required unless it is expressly requested by the boiler manufacturer.

**5.5 Securing the burner to the boiler (Fig. 8)**

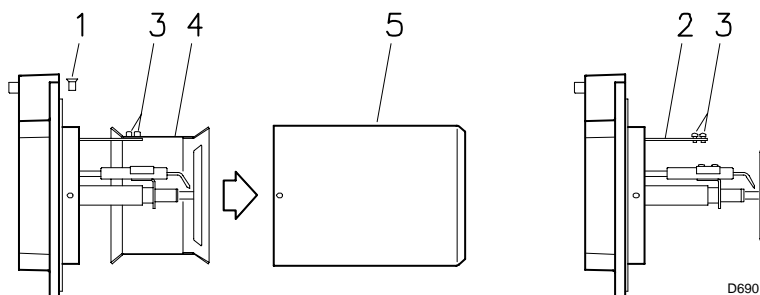

Fig. 8

Disassemble the blast tube 9) from the burner 6) by proceeding as follows:

- Loosen the four screws 3) and remove the cover 1).
- Remove the screws 2) from the two slide bars 5).
- Remove the two screws 4) fixing the burner 6) to the flange 7).
- Withdraw the blast tube 9) complete with flange 7) and slide bars 5).

Once this operation has been carried out (if it was required), secure flange 7) (Fig. 7) to the boiler plate interposing the supplied gasket 8). Use the 4 screws provided after having protected the thread with anti-seize products (high-temperature grease, compounds, graphite).

The burner-boiler seal must be airtight.

**Combustion head calibration**

At this point check, for model RL 130, whether the maximum delivery of the burner in 2nd stage operation is contained in area B or in area C of the firing rate. See pag. 9.

If it is in area B then no operation is required.

If, on the other hand, it is in area C:

- Unscrew the screws 1) (Fig. 8) and disassemble the blast tube 5)
- Unscrew the screws 3) and remove the shutter 4)
- Tighten the screws 3) on the rod 2)
- Now refit the blast tube 5) and the screws 1)

### 5.6 Choice of nozzles for 1st and 2nd stage

Both nozzles must be chosen from among those listed in table (Tab. B).

**The first nozzle** determines the delivery of the burner in the 1st stage.

**The second nozzle** works together with the 1st nozzle to determine the delivery of the burner in the 2nd stage.

The deliveries of the 1st and 2nd stages must be contained within the value range indicated on pag. 6.

Use nozzles with a 60° spray angle at the recommended pressure of 12 bar.

The two nozzles usually have equal deliveries, but the 1st stage nozzle may have the following specifications if required:

- a delivery less than 50% of the total delivery whenever the back-pressure peak must be reduced at the moment of firing: the burner allows good combustion values also with a ratio 40 - 100 % between the 1st and 2nd stage;
- a delivery higher than 50% of the total delivery whenever the combustion during the 1st stage must be improved.

**Example** with the RL 70 model:

Boiler output = 635 kW - efficiency 90 %

Output required by the burner =

$$635 : 0,9 = 705 \text{ kW}$$

$$705 : 2 = 352 \text{ kW per nozzle};$$

therefore, two equal, 60°, 12 bar nozzles are required:

$$1^\circ = 7,0 \text{ GPH} - 2^\circ = 7,0 \text{ GPH},$$

or the following two different nozzles:

$$1^\circ = 6,0 \text{ GPH} - 2^\circ = 8,0 \text{ GPH},$$

or:

$$1^\circ = 8,0 \text{ GPH} - 2^\circ = 6,0 \text{ GPH},$$

GPH	kg/h (1)			kW 12 bar
	10 bar	12 bar	14 bar	
5.00	19.2	21.2	23.1	251.4
5.50	21.1	23.3	25.4	276.3
6.00	23.1	25.5	27.7	302.4
6.50	25.0	27.6	30.0	327.3
7.00	26.9	29.7	32.3	352.3
7.50	28.8	31.8	34.6	377.2
8.00	30.8	33.9	36.9	402.1
8.30	31.9	35.2	38.3	417.5
8.50	32.7	36.1	39.2	428.2
9.00	34.6	38.2	41.5	453.1
9.50	36.5	40.3	43.8	478.0
10.0	38.4	42.4	46.1	502.9
10.5	40.4	44.6	48.4	529.0
11.0	42.3	46.7	50.7	553.9
12.0	46.1	50.9	55.3	603.7
12.3	47.3	52.2	56.7	619.1
13.0	50.0	55.1	59.9	653.5
13.8	53.1	58.5	63.3	693.8
14.0	53.8	59.4	64.5	704.5
15.0	57.7	63.6	69.2	754.3
15.3	58.8	64.9	70.5	769.7
16.0	61.5	67.9	73.8	805.3
17.0	65.4	72.1	78.4	855.1
17.5	67.3	74.2	80.7	880.0
18.0	69.2	76.4	83.0	906.1
19.0	73.0	80.6	87.6	956.0
19.5	75	82.7	89.9	980.9
20.0	76.9	84.8	92.2	1005.8
21.5	82.7	91.2	99.1	1081.7
22.0	84.6	93.3	101.4	1106.6

**Tab. B**

(1) light oil: density 0.84 kg/dm<sup>3</sup> - viscosity 4.2 cSt/20 °C - temperature 10 °C

5.7 Nozzle assembly

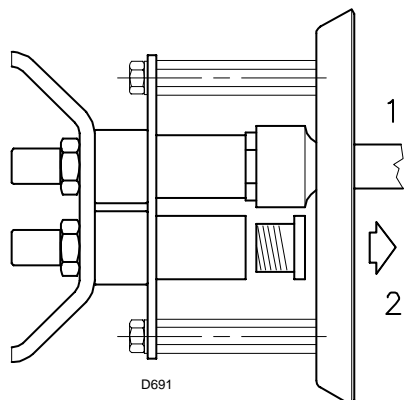

Fig. 9

At this stage of installation the burner is still disassembled from the blast tube; it is therefore possible to fit two nozzles with the box spanner 1)(Fig. 9) (16 mm), after having removed the plastic plugs 2)(Fig. 9), fitting the spanner through the central hole in the flame stability disk. Do not use any sealing products such as gaskets, sealing compound, or tape. Be careful to avoid damaging the nozzle sealing seat. The nozzles must be screwed into place tightly but not to the maximum torque value provided by the wrench.

The nozzle for the 1st stage of operation is the one lying beneath the firing electrodes (Fig. 10)

Make sure that the electrodes are positioned as shown in (Fig. 10)

Finally refit the burner 3)(Fig. 11) to the slide bars 2) and slide it up to the flange 5), **keeping it slightly raised to prevent the flame stability disk from pressing against the blast tube.**

Tighten the screws 1) on the slide bars 2) and screws 4) fixing the burner to the flange.

If it proves necessary to change a nozzle with the burner already fitted to the boiler, proceed as outlined below:

- Retract the burner on its slide bars as shown in (Fig. 7 pag. 11).
- Remove the nuts 1) (Fig. 12) and the disk 2).
- Use spanner 3)(Fig. 12) to change the nozzles.

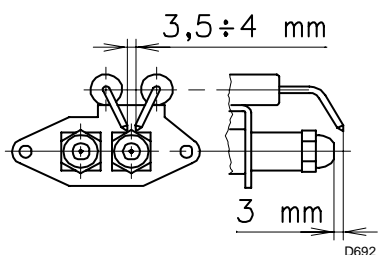

Fig. 10

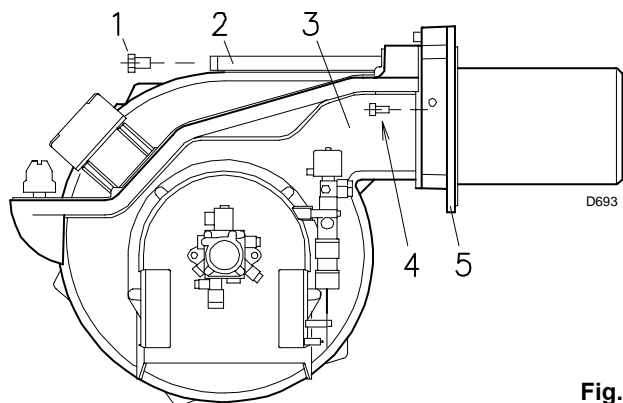

Fig. 11

**NOTE:**

**The supplied nozzles can be used when meeting the required delivery only. Otherwise they must be replaced with complying nozzles.**

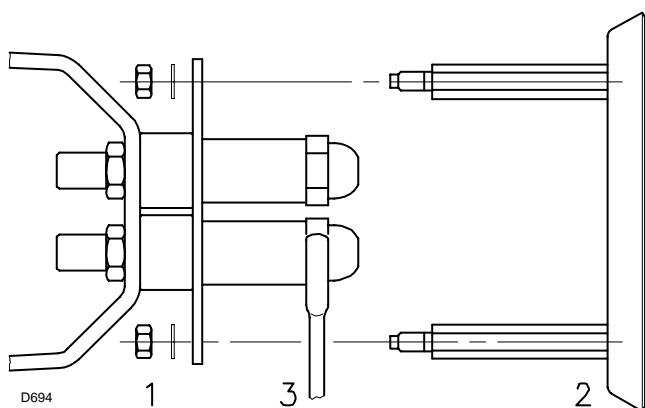
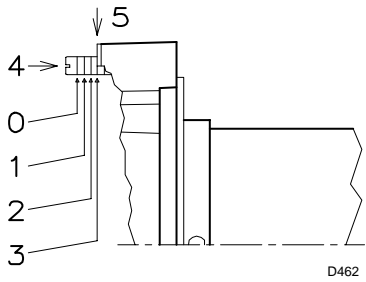

Fig. 12

**5.8 Combustion head setting**



**Fig. 13**

The setting of the combustion head depends exclusively on the delivery of the burner in the 2nd stage - in other words, the combined delivery of the two nozzles selected on pag. 12.

Turn screw 4)(Fig. 13) until the notch shown in diagram (Fig. 14) is level with the front surface of flange 5)(Fig. 13).

**Example:**

The RL 70 Model with two 6.0 GPH nozzles and 12 bar pump pressure.

Find the delivery of the two 6.0 GPH nozzles in (Tab. B pag. 12):  
 $25.5 + 25.5 = 51 \text{ kg/h}$ .

Diagram Fig. 14 indicates that for a delivery of 51 kg/h the RL 70 Model requires the combustion head to be set to approx. three notches, as shown in Fig. 13

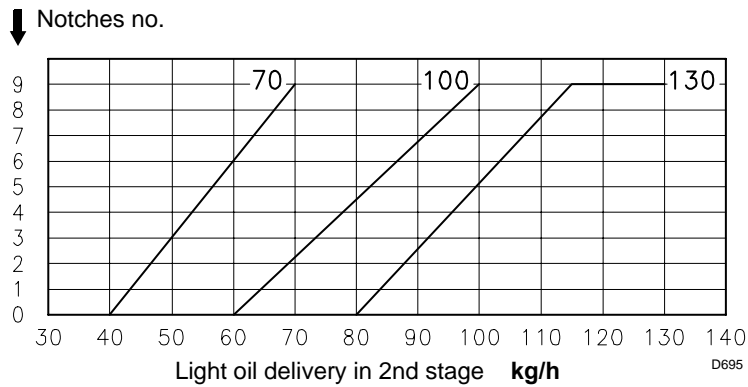

**Fig. 14**



**6 Electrical system****Notes on safety for the electrical wiring**

- The electrical wiring must be carried out with the electrical supply disconnected.
- Electrical wiring must be carried out by qualified personnel and in compliance with the regulations currently in force in the country of destination. Refer to the wiring diagrams.
- **RIELLO** declines all responsibility for modifications or connections different from those shown in the electrical layouts.
- Do not invert the neutral with the phase in the electrical supply line. Any inversion would cause a lockout due to firing failure.
- The RL 70-100-130 burners have been type-approved for intermittent operation. This means they should compulsorily be stopped at least once every 24 hours to enable the control box to perform checks of its own start-up efficiency. Normally the boiler's thermostat/pressure switch ensures the stopping of the burner. If this is not the case, it is necessary to apply in series with IN a timer switch that turns off the burner at least once every twenty-four hours. Refer to the wiring diagrams.
- The electrical safety of the device is obtained only when it is correctly connected to an efficient earthing system, made according to current standards. It is necessary to check this fundamental safety requirement. In the event of doubt, have the electrical system checked by qualified personnel.
- The electrical system must be suitable for the maximum input power of the device, as indicated on the label and in the manual, checking in particular that the section of the cables is suitable for the input power of the device.
- For the main power supply of the device from the electricity mains:
  - do not use adapters, multiple sockets or extensions;
  - use an omnipolar switch with an opening of at least 3 mm (overvoltage category) between the contacts, as indicated by the current safety standards.
- Do not touch the device with wet or damp body parts and/or in bare feet.
- Do not pull the electric cables.

### 6.1 Electrical system (factory set)

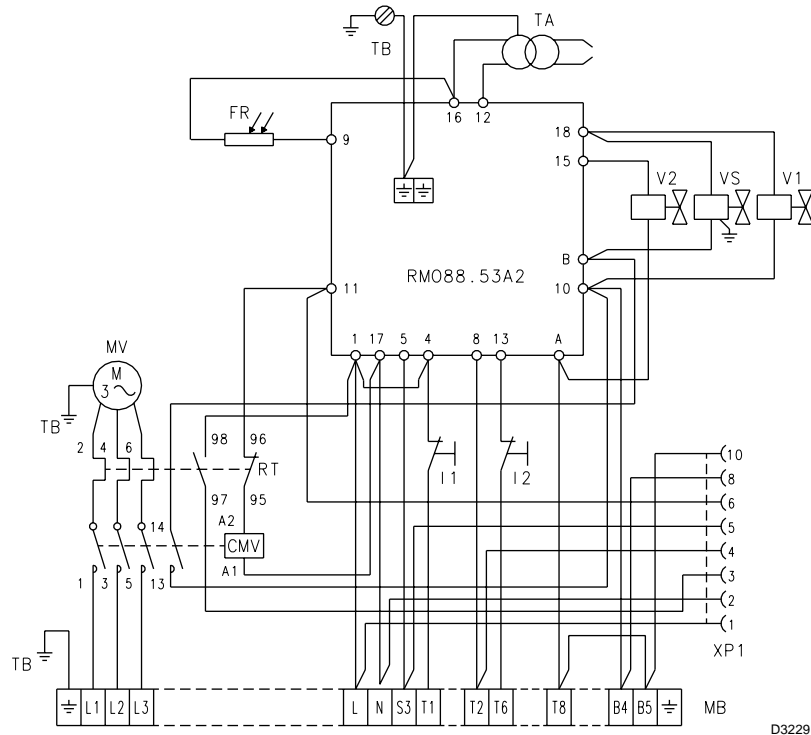

Fig. 15

#### Burners RL 70 - RL 100 - RL 130

- Models RL 70 - 100 - 130 leave the factory preset for 400 V power supply.
- If 230 V power supply is used, change the motor connection from star to delta and change the setting of the thermal cut-out as well.

#### Key to wiring diagram (Fig. 15)

- CMV - Motor contactor
- FR - Photoresistor
- I1 - Switch: burner off - on
- I2 - Switch: 1st - 2nd stage operation
- MB - Terminal strip
- MV - Fan motor
- RMO88.53A2 - Control box
- RT - Thermal cut-out
- TA - Ignition transformer
- TB - Burner ground (earth) connection
- V1 - 1st stage solenoid valve
- V2 - 2nd stage solenoid valve
- VS - Safety solenoid valve
- XP1 - Connector for STATUS

#### NOTE:

For remote-reset, connect a push-button switch (NO) between terminal 3 and neutral of the control box (terminals 15, 16, 17 and 18).

#### 6.1.1 Electrical connections (Fig. 16)

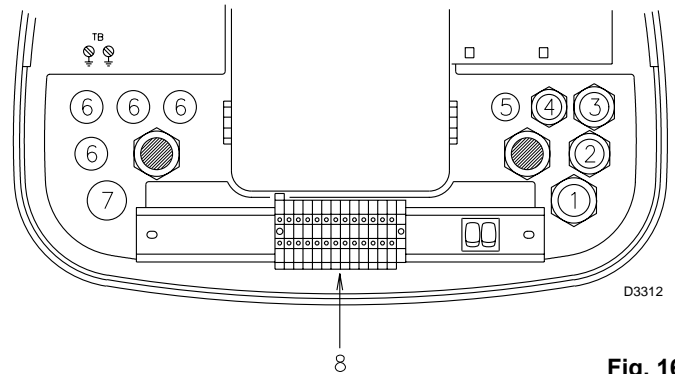

Fig. 16

Set up by the installer

Use flexible cables according to regulation EN 60 335-1:

- if in PVC boot, use at least H05 VV-F
- if in rubber boot, use at least H05 RR-F.

All the cables to be connected to the burner terminal strip 8)(Fig. 16) must be routed through the fairleads.

The fairleads and precut holes can be used in various ways. One example is given below:

- |   |         |  |
|---|---------|--|
| 1 | Pg 13,5 | Three-phase power supply               |
| 2 | Pg 11   | Single-phase power supply              |
| 3 | Pg 11   | Control device TL                      |
| 4 | Pg 9    | Control device TR                      |
| 5 | Pg 9    | Fitting hole for fairlead, if required |
| 6 | Pg 11   | Fitting hole for fairlead, if required |
| 7 | Pg 13,5 | Fitting hole for fairlead, if required |

**RL 70 - 100 - 130 Models electrical connection three-phase 230/400 V power supply with neutral phase wire.**

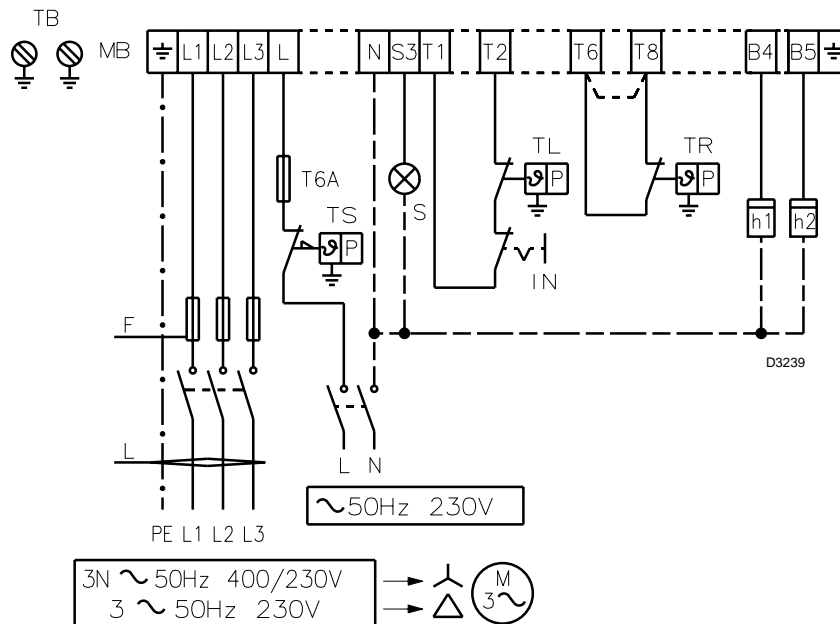

Fig. 17

		RL 70		RL 100		RL 130	
		230 V	400 V	230 V	400 V	230 V	400 V
F	A	T10	T6	T16	T10	T16	T10
L	mm <sup>2</sup>	1.5	1.5	1.5	1.5	1.5	1.5

Fuses and cables section layout, see table (Fig. 17).

Cable section not indicated: 1.5 mm<sup>2</sup>.

**Key to wiring diagram (Fig. 17)**

- H1 - 1st stage hourcounter
- H2 - 2nd stage hourcounter
- IN - Manual burner stop switch
- MB - Terminal strip
- S - Remote lock-out signal
- TB - Burner ground (earth) connection
- TL - Limit control device system: this shuts down the burner when the boiler temperature or pressure exceeds the set-point value.
- TR - High-low mode control device system: this controls operating stages 1 and 2 and is necessary only for two-stage operation.
- TS - Safety control device system: this operates when TL is faulty.



The burner is factory set for two-stage operation and the TR remote control device that commands light oil valve V2 must therefore be connected.

**WARNING**

Alternatively, if single stage operation is required, instead of control device TR install a jumper lead between terminal 5 and 6 of the terminal strip.

**Calibration of thermal cut-out 17)(Fig. 1 pag. 7)**

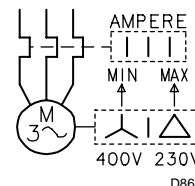

Fig. 18

This is required to avoid motor burn-out in the event of a significant increase in power absorption caused by a missing phase.

- If the motor is star-powered, **400 V**, the cursor should be positioned to "MIN".
- If the motor is delta-powered, **230 V**, the cursor should be positioned to "MAX".

Even if the scale of the thermal cut-out does not include rated motor absorption at 400 V, protection is still ensured in any case.

**NOTE:**

**Burners RL 70 - 100 - 130 leave the factory preset for 400 V power supply. If 230 V power supply is used, change the motor connection from star to delta and change the setting of the thermal cut-out as well. The RL 70 - 100 - 130 burners have been type-approved for intermittent operation. This means they should compulsorily be stopped at least once every 24 hours to enable the control box to perform checks of its own efficiency at start-up. Burner halts are normally provided for automatically by the boiler load control system. If this is not the case, it is necessary to apply in series with IN a timer switch that turns off the burner at least once every twenty-four hours.**



Do not invert the neutral with the phase in the electrical supply line.

**WARNING**

**7 Hydraulic system**

**7.1 Fuel supply**

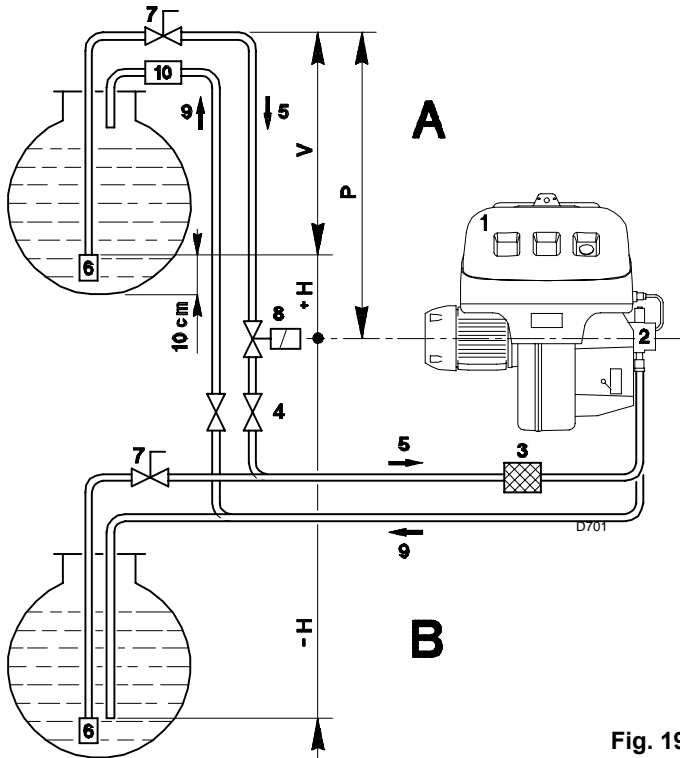

**Fig. 19**

**Double-pipe circuit (Fig. 19)**

The burner is equipped with a self-priming pump which is capable of feeding itself within the limits listed in the table at the side.

**The tank higher than the burner A**

The distance "P" must not exceed 10 meters in order to avoid subjecting the pump's seal to excessive strain; the distance "V" must not exceed 4 meters in order to permit pump self-priming even when the tank is almost completely empty.

**The tank lower than the burner B**

Pump depression of 0.45 bar (35 cm Hg) must not be exceeded because at higher levels gas is released from the fuel, the pump starts making noise and its working life-span decreases.

It is good practice to ensure that the return and suction lines enter the burner from the same height; in this way it will be less probable that the suction line fails to prime or stops priming.

**The loop circuit**

A loop circuit consists of a loop of piping departing from and returning to the tank with an auxiliary pump that circulates the fuel under pressure. A branch connection from the loop goes to feed the burner. This circuit is extremely useful whenever the burner pump does not succeed in self-priming because the tank distance and/or height difference are higher than the values listed in the table.

+ H - H (m)	L (m)					
	RL 70 Ø (mm)			RL 100 - 130 Ø (mm)		
	10	12	14	12	14	16
+ 4.0	51	112	150	71	138	150
+ 3.0	45	99	150	62	122	150
+ 2.0	39	86	150	53	106	150
+ 1.0	32	73	144	44	90	150
+ 0.5	29	66	132	40	82	150
0	26	60	120	36	74	137
- 0.5	23	54	108	32	66	123
- 1.0	20	47	96	28	58	109
- 2.0	13	34	71	19	42	81
- 3.0	7	21	46	10	26	53
- 4.0	-	8	21	-	10	25

**Tab. C**

**Key**

- H = Pump/Foot valve height difference
- L = Piping length
- Ø = Inside pipe diameter
- 1 = Burner
- 2 = Pump
- 3 = Filter
- 4 = Manual on/off valve
- 5 = Suction line
- 6 = Foot valve
- 7 = Rapid closing manual valve - remote controlled (only Italy)
- 8 = On/off solenoid valve (only Italy)
- 9 = Return line
- 10 = Check valve (only Italy)

**7.2 Hydraulic connections (Fig. 20)**

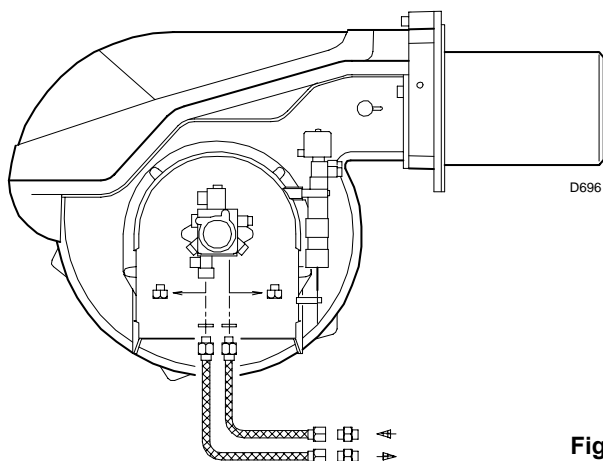

**Fig. 20**

The pumps are equipped with a by-pass that connects return line with suction line. The pumps are installed on the burner with the by-pass closed by screw 6) (Fig. 27 pag. 22).

It is therefore necessary to connect both hoses to the pump.

The pump will break down immediately if it is run with the return line closed and the by-pass screw inserted.

Remove the plugs from the suction and return connections of the pump.

Insert the hose connections with the supplied seals into the connections and screw them down.

Take care that the hoses are not stretched or twisted during installation.

Install the hoses where they cannot be stepped on or come into contact with hot surfaces of the boiler.

Now connect the other end of the hoses to the supplied nipples, using two wrenches, one to hold the nipple steady while using the other one to turn the rotary union on the hose.

**RL 70**  
PUMP SUNTEC AL 95 C

**RL 100 - RL 130**  
PUMP SUNTEC AJ6 CC

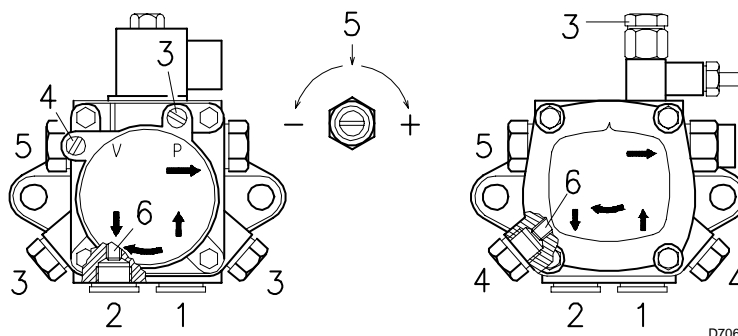

**Fig. 21**

**7.3 Pump (Fig. 21)**

- 1 - Suction G 1/4"
  - 2 - Return G 1/4"
  - 3 - Pressure gauge connection G 1/8"
  - 4 - Vacuum meter connection G 1/8"
  - 5 - Pressure adjustment screw
  - 6 - Screw for by-pass
- A - Min. delivery rate at 12 bar pressure
  - B - Delivery pressure range
  - C - Max. suction depression
  - D - Viscosity range
  - E - Light oil max. temperature
  - F - Max. suction and return pressure
  - G - Pressure calibration in the factory
  - H - Filter mesh width

**7.3.1 Pump priming**

- Before starting the burner, make sure that the tank return line is not clogged. Obstructions in the line could cause the sealing organ located on the pump shaft to break. (The pump leaves the factory with the by-pass closed).
- In order for self-priming to take place, one of the screws 3) (Fig. 21) of the pump must be loosened in order to bleed off the air contained in the suction line.
- Start the burner by closing the control devices and with switch 1) (Fig. 22 pag. 20) in the "ON" position. The pump must rotate in the direction of the arrow marked on the cover.

- The pump can be considered to be primed when the light oil starts coming out of the screw 3). Stop the burner: switch 1) (Fig. 22 pag. 20) set to "OFF" and tighten the screw 3).

The time required for this operation depends upon the diameter and length of the suction tubing. If the pump fails to prime at the first starting of the burner and the burner locks out, wait approx. 15 seconds, reset the burner, and then repeat the starting operation as often as required. After 5 or 6 starting operations allow 2 or 3 minutes for the transformer to cool.

Do not illuminate the photoresistor or the burner will lock out; the burner should lock out anyway about 10 seconds after it starts.



The a.m. operation is possible because the pump is already full of fuel when it leaves the factory. If the pump has been drained, fill it with fuel through the opening on the vacuum meter prior to starting; otherwise, the pump will seize.

Whenever the length of the suction piping exceeds 20-30 meters, the supply line must be filled using a separate pump.

**8 Burner calibration**

**8.1 Firing**

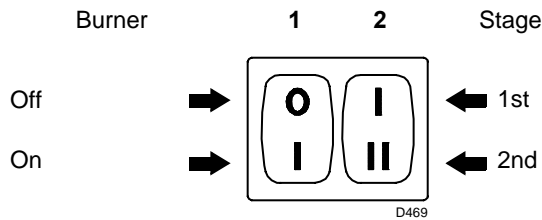

**Fig. 22**



**WARNING**

Check the correct working of the adjustment, command and safety devices.

Set switch 1) (Fig. 22) to "ON".

During the first firing, during the passage from the 1st to the 2nd stage, there is a momentary lowering of the fuel pressure caused by the filling of the 2nd stage nozzle tubing. This lowering of the fuel pressure can cause the burner to lock-out and can sometimes give rise to pulsations.

Once the following adjustments have been made, the firing of the burner must generate a noise similar to the noise generated during operation. If one or more pulsations or a delay in firing in respect to the opening of the light oil solenoid valve occur, see the suggestions provided on pag. 26: causes 34 ÷ 42

**Notes on safety for the first start-up**



**WARNING**

The first start-up of the burner must be carried out by qualified personnel, as indicated in this manual and in compliance with the standards and regulations of the laws in force.

**8.2 Operation**

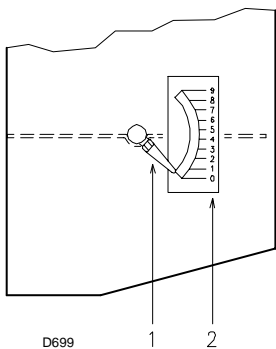

**Fig. 23**

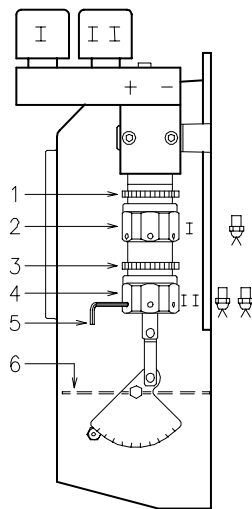

**Fig. 24**

**14 bar:** order to increase fuel delivery or to ensure firings even at temperatures of less than 0°C.

In order to adjust pump pressure, use the relevant screw 5) (Fig. 21 pag. 19)

► **1st stage fan air gate valve**

Keep the burner operating at 1st stage by setting the switch 2) (Fig. 22) to the 1st stage position. Opening of the air gate valve 6) (Fig. 24) must be adjusted in proportion to the selected nozzle: the index 1) (Fig. 23) must be aligned with the notch 2) (Fig. 23) specified in table (Tab. D) This adjustment is achieved by turning the hex element 2) (Fig. 24):

- in rh direction (- sign) the opening is reduced;
- in lh direction (+ sign) the opening increases.

**Example: RL 70 - 1st stage nozzle 6.0 GPH:**

2.3 notch (Fig. 23) aligned with index 1).

When the adjustment is terminated lock the hex element 2) (Fig. 24) with the ring nut 1).

RL 70		RL 100		RL 130	
GPH	N°	GPH	N°	GPH	N°
5	2.0	7	2.0	10	2.0
6	2.3	8	2.1	11	2.1
7	2.6	9	2.2	12	2.2
8	2.7	10	2.4	13	2.3
9	2.8	11	2.6	14	2.5
		12	2.7	15	2.6
		13	2.8	16	2.7
		14	2.9	17	2.8
				18	2.9
				19	3.0

**Tab. D**

N° = Notch 2) (Fig. 23)

The optimum calibration of the burner requires an analysis of the flue gases at the boiler outlet and interventions on the following points:

► **1st and 2nd stage nozzles**

See the information listed on pag. 12.

► **Combustion head**

The adjustment of the combustion head already carried out need not be altered unless the 2nd stage delivery of the burner is changed.

► **Pump pressure**

**12 bar:** this is the pressure calibrated in the factory which is usually sufficient for most purposes. Sometimes, this pressure must be adjusted to:

**10 bar:** in order to reduce fuel delivery. This adjustment is possible only if the surrounding temperature remains above 0°C. Never calibrate to pressures below 10 bar, at which pressures the cylinders may have difficulty in opening;

► **2st stage fan air gate valve**

Set switch 2) (Fig. 22 pag. 20) to the 2nd stage position and adjust the air gate valve 6)(Fig. 24) by turning the hex element 4)(Fig. 24), after having loosened the ring nut 3)(Fig. 24).

Air pressure at connection 1)(Fig. 25) must be approximately the same as the pressure specified in the table (Fig. 25) plus the combustion chamber pressure measured at connection 2). Refer to the example in the adjacent figure.

RL 70		RL 100		RL 130	
kg/h	mbar	kg/h	mbar	kg/h	mbar
40	8.5	60	7.2	80	7
50	8.6	70	7.7	90	7.2
60	8.8	80	8.4	100	7.6
70	9.2	90	9.3	110	8.1
		100	11.0	120	9.0
				130	11.0
				130	8.5 <sup>(1)</sup>

**Tab. E**

mbar = air pressure in 1) with zero pressure in 2)

(1) With shutter 4) retracted (Fig. 8 pag. 11)

**NOTE:**

in order to facilitate adjustment of hex elements 2) and 4)(Fig. 24), use a 3 mm Allen key 5) (Fig. 24).

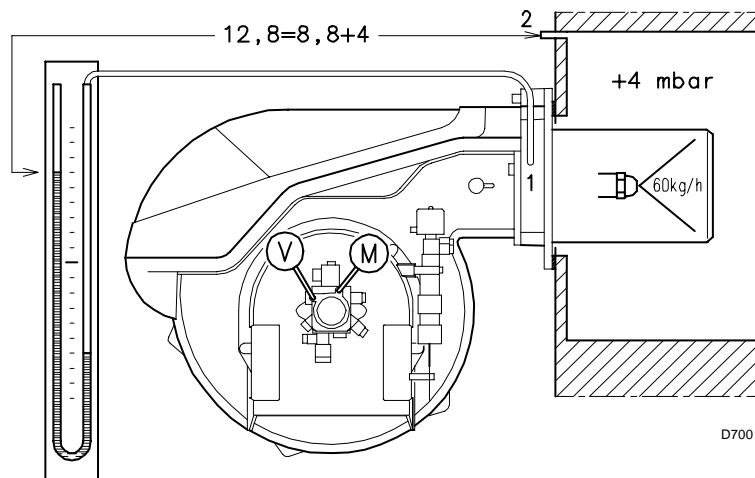

**Fig. 25**

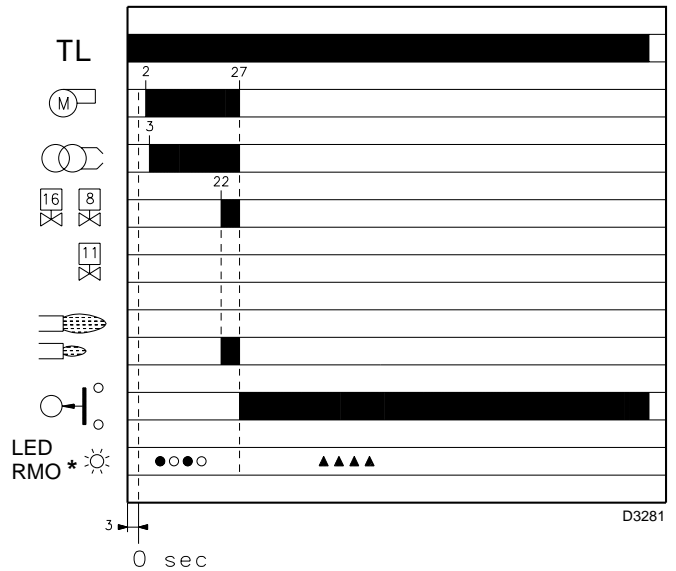
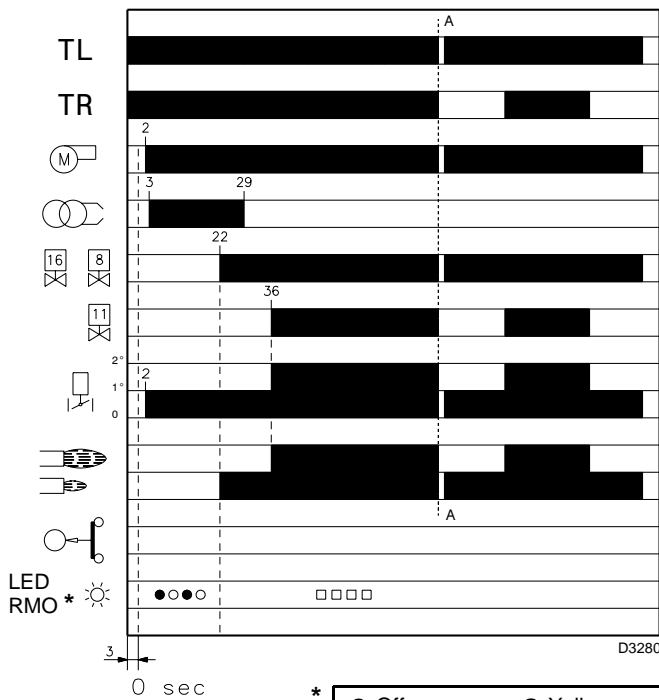

\* ○ Off      ● Yellow      □ Green      ▲ Red  
For further details see pag. 25.

**Fig. 26**



**8.2.1 Burner starting (Fig. 26) - (Fig. 27)**

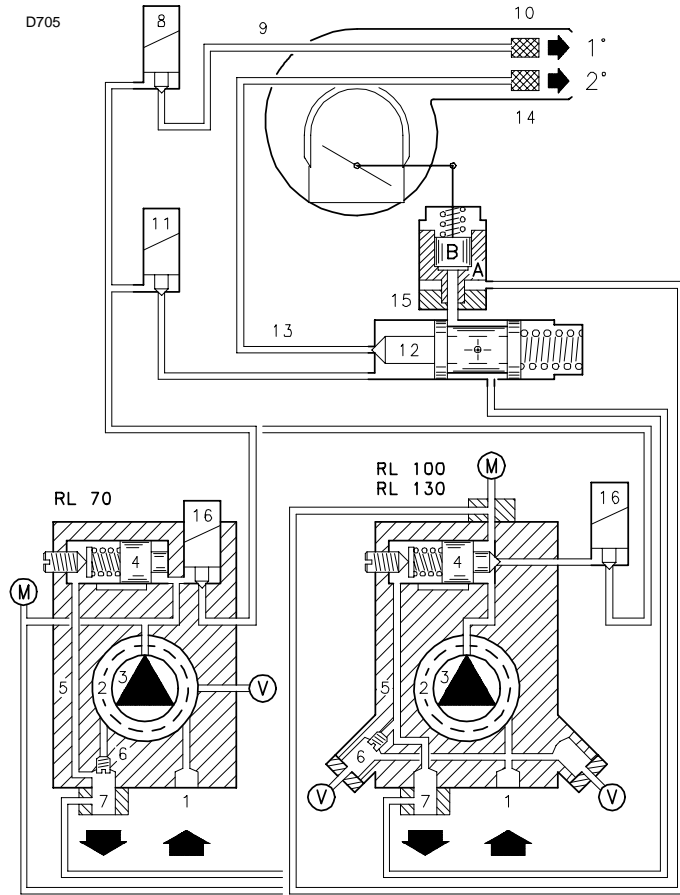

**Fig. 27**

Starting phases with progressive time intervals shown in seconds:

Control device TL closes.

After about 3s:

- **0 s** : The control box starting cycle begins.
- **2 s** : The fan motor starts.
- **3 s** : The ignition transformer is connected. The pump 3) sucks the fuel from the tank through the piping 1) and the filter 2) and pumps it under pressure to delivery. The piston 4) rises and the fuel returns to the tank through the piping 5) - 7). The screw 6) closes the by-pass heading towards suction and the solenoid valves 8) - 11) - 16), de-energized, close the passage to the nozzles. The hydraulic cylinder 15), piston A, opens the air gate valve: pre-purging begins with the 1st stage air delivery.
- **22 s** : Solenoid valves 8) and 16) open and the fuel passes through the piping 9) and filter 10) and is then sprayed out through the nozzle, igniting when it comes into contact with the spark. This is the 1st stage flame.
- **29 s** : The ignition transformer switches off.
- **36 s** : If the control device TR is closed or has been replaced by a jumper wire, the 2nd stage solenoid valve 11) is opened and the fuel enters the device 12) and raises the piston which opens two passages: one to piping 13), filter 14), and the 2nd stage nozzle, and the other to the cylinder 15), piston B, that opens the fan air gate valve in the 2nd stage. The starting cycle comes to an end.

**8.2.2 Steady state operation**

**System equipped with one control device TR**

Once the starting cycle has come to an end, the command of the 2nd stage solenoid valve passes on to the control device TR that controls boiler temperature or pressure.

- When the temperature or the pressure increases until the control device TR opens, solenoid valve 11) closes, and the burner passes from the 2nd to the 1st stage of operation.
- When the temperature or pressure decreases until the control device TR closes, solenoid valve 11) opens, and the burner passes from the 1st to the 2nd stage of operation. And so on.
- The burner stops when the demand for heat is less than the amount of heat delivered by the burner in the 1st stage. In this case, the control device TL opens, and solenoid valves 8)-16) close, the flame immediately goes out. The fan's air gate valve closes completely.

**Systems not equipped with control device TR (jumper wire installed)**

The burner is fired as described in the case above. If the temperature or pressure increase until control device TL opens, the burner shuts down (Section A-A in the diagram).

When the solenoid valve 11) de-energizes, the piston 12) closes the passage to the 2nd stage nozzle and the fuel contained in the cylinder 15), piston B, is discharged into the return piping 7).

**8.2.3 Firing failure**

If the burner does not fire, it goes into lock-out within 5 s of the opening of the 1st stage valve and 30 s after the closing of control device TL.

The control box red pilot light will light up.

**8.2.4 Undesired shutdown during operation**

If the flame goes out during operation, the burner shuts down automatically within 1 second and automatically attempts to start again by repeating the starting cycle.

**8.2.5 Final checks**

- **Darken the photoresistor and switch on the control devices:** the burner should start and then lock-out about 5 s after opening of the 1st stage operation valve.
- **Illuminate the photoresistor and switch on the control devices:** the burner should start and then go into lock-out after about 10 s.
- **Darken the photoresistor while the burner is in 2nd stage operation, the following must occur in sequence:** flame extinguished within 1 s, pre-purging for about 20 s, sparking for about 5 s, burner goes into lock out.
- **Switch off control device TL followed by control device TS while the burner is operating:** the burner should stop.



## 9 Maintenance

### Notes on safety for the maintenance

The periodic maintenance is essential for the good operation, safety, yield and duration of the burner.

It allows you to reduce consumption and polluting emissions and to keep the product in a reliable state over time.



The maintenance interventions and the calibration of the burner must only be carried out by qualified, authorised personnel, in accordance with the contents of this manual and in compliance with the standards and regulations of current laws.

Before carrying out any maintenance, cleaning or checking operations:



disconnect the electricity supply from the burner by means of the main switch of the system;



close the fuel interception tap;

### Combustion

The optimum calibration of the burner requires an analysis of the flue gases. Significant differences with respect to the previous measurements indicate the points where more care should be exercised during maintenance.

### Pump

**The delivery pressure** must be stable at 12 bar.

**The depression** must be less than 0.45 bar.

**Unusual noise** must not be evident during pump operation.

If the pressure is found to be unstable or if the pump runs noisily, the flexible hose must be detached from the line filter and the fuel must be sucked from a tank located near the burner. This measure permits the cause of the anomaly to be traced to either the suction piping or the pump.

If the pump is found to be responsible, check to make sure that the filter is not dirty. The vacuum meter is installed upstream from the filter and consequently will not indicate whether the filter is clogged or not.

Contrarily, if the problem lies in the suction line, check to make sure that the filter is clean and that air is not entering the piping.

### Filters (Fig. 28)

Check the following filter boxes:

- on line 1) • in the pump 2) • at the nozzle 3), and clean or replace as required.

If rust or other impurities are observed inside the pump, use a separate pump to lift any water and other impurities that may have deposited on the bottom of the tank.

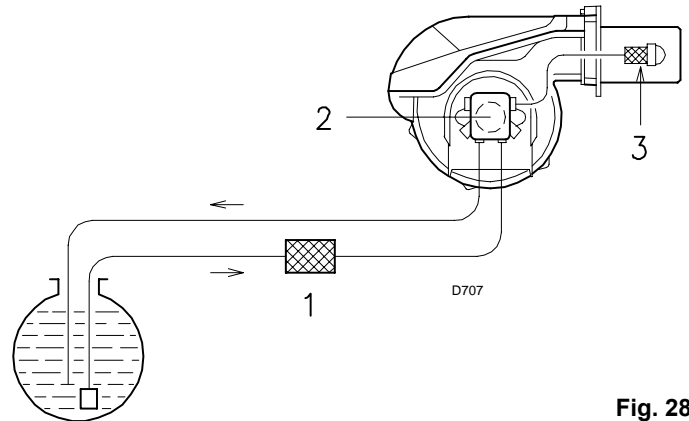

Fig. 28

### Fan

Check to make sure that no dust has accumulated inside the fan or on its blades, as this condition will cause a reduction in the air flow rate and provoke polluting combustion.

### Combustion head

Check to make sure that all the parts of the combustion head are in good condition, positioned correctly, free of all impurities, and that no deformation has been caused by operation at high temperatures.

### Nozzles

Do not clean the nozzle openings; do not even open them.

Replace the nozzles every 2-3 years or whenever necessary. Combustion must be checked after the nozzles have been changed.

### Photoresistor (Fig. 29)

Clean the glass cover from any dust that may have accumulated. Photoresistor 1) is held in position by a pressure fit and can therefore be removed by pulling it outward forcefully.

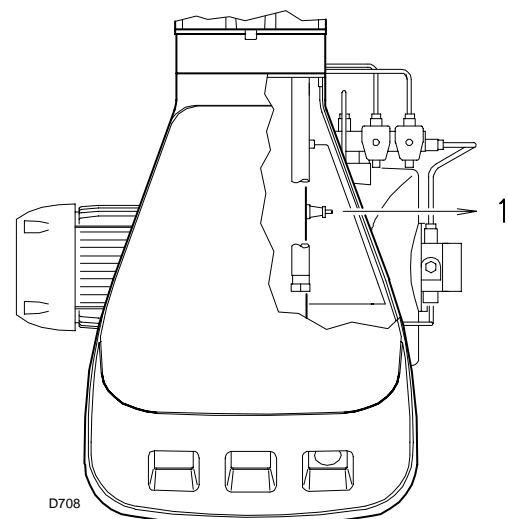
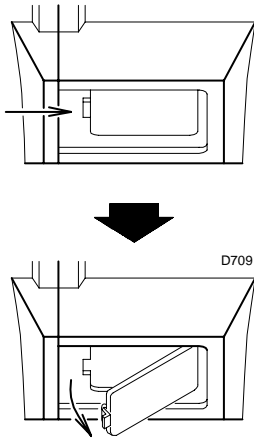

Fig. 29

**Flame inspection window (Fig. 30)**

Clean the glass whenever necessary.



**Fig. 30**

**Fuel pump and/or couplings replacement (Fig. 32)**

In conformity with figures (Fig. 32)

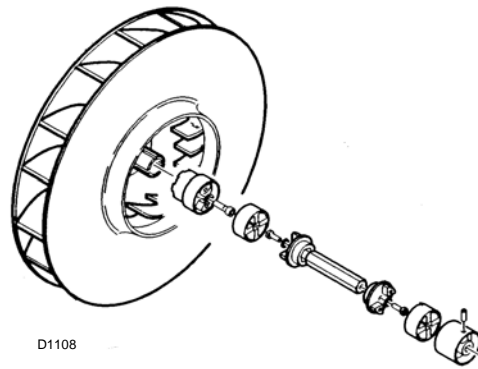

**Fig. 32**

**Flexible hoses**

Check to make sure that the flexible hoses are still in good condition and that they are not crushed or otherwise deformed.

**Fuel tank**

Approximately every 5 years, or whenever necessary, suck any water or other impurities present on the bottom of the tank using a separate pump.

**Boiler**

Clean the boiler as indicated in its accompanying instructions in order to maintain all the original combustion characteristics intact, especially the flue gas temperature and combustion chamber pressure.

**To open the burner (Fig. 31)**

Switch off the electrical power.  
 Remove screws 1) and withdraw the casing 2).  
 Unscrew the screws 3).  
 Fit the two extensions 4) supplied with the burner onto the slide bars 5) (model with 385 mm blast tube).  
 Pull part A backward keeping it slightly raised to avoid damaging the disk 6) on blast tube 7).

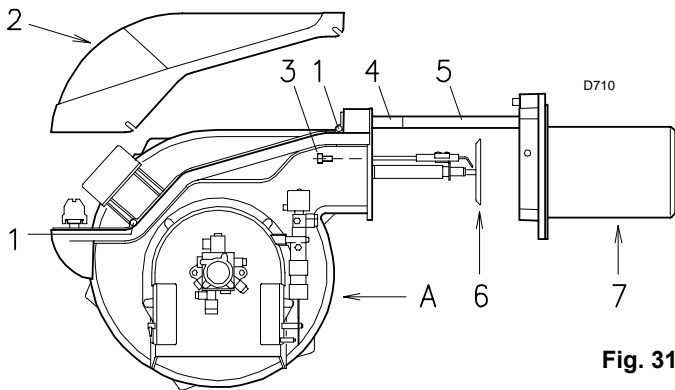

**Fig. 31**

### 9.1 Burner start-up cycle diagnostics

During start-up, indication is according to the following table:

Sequences	Colour code
Pre-purging	● ○ ● ○ ● ○ ● ○ ●
Ignition phase	● ○ ● ○ ● ○ ● ○ ●
Operation, flame ok	□ □ □ □ □ □ □ □ □
Operating with weak flame signal	□ ○ □ ○ □ ○ □ ○ □
Electrical supply lower than ~ 170V	● ▲ ● ▲ ● ▲ ● ▲ ●
Lock-out	▲ ▲ ▲ ▲ ▲ ▲ ▲ ▲ ▲
Extraneous light	▲ □ ▲ □ ▲ □ ▲ □ ▲

**Key:**      ○ Off                  ● Yellow                  □ Green                  ▲ Red

### 9.2 Resetting the control box and using diagnostics

The control box features a diagnostics function through which any causes of malfunctioning are easily identified (indicator: **RED LED**). To use this function, you must wait at least 10 seconds once it has entered the safety condition (**lock-out**), and then press the reset button.

The control box generates a sequence of pulses (1 second apart), which is repeated at constant 3-second intervals.

Once you have seen how many times the light pulses and identified the possible cause, the system must be reset by holding the button down for between 1 and 3 seconds.

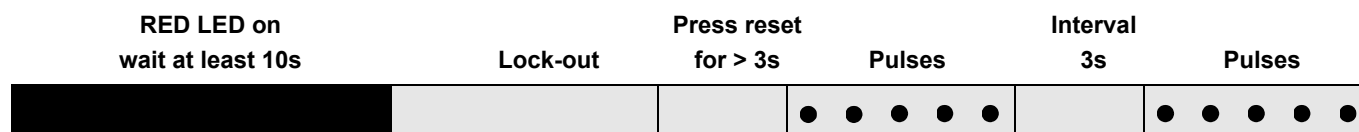

The methods that can be used to reset the control box and use diagnostics are given below.

### 9.3 Resetting the control box

To reset the control box, proceed as follows:

- Hold the button down for between 1 and 3 seconds.  
The burner restarts after a 2-second pause once the button is released.  
If the burner does not restart, you must make sure the limit thermostat is closed.

### 9.4 Visual diagnostics

Indicates the type of burner malfunction causing lock-out.

To view diagnostics, proceed as follows:

- Hold the button down for more than 3 seconds once the red LED (burner lock-out) remains steadily lit.  
A yellow light pulses to tell you the operation is done.  
Release the button once the light pulses. The number of times it pulses tells you the cause of the malfunction, according to the coding system indicated in the table on pag. 26.

**9.5 Software diagnostics**

Reports burner life by means of an optical link with the PC, indicating hours of operation, number and type of lock-outs, serial number of control box etc.

To view diagnostics, proceed as follows:

- Hold the button down for more than 3 seconds once the red LED (burner lock-out) remains steadily lit.  
A yellow light pulses to tell you the operation is done.  
Release the button for 1 second and then press again for over 3 seconds until the yellow light pulses again.  
Once the button is released, the red LED will flash intermittently with a higher frequency: only now can the optical link be activated.

Once the operations are done, the control box's initial state must be restored using the resetting procedure described above.

Button pressed for	Control box status
Between 1 and 3 seconds	Control box reset without viewing visual diagnostics.
More than 3 seconds	Visual diagnostics of lock-out condition: (LED pulses at 1-second intervals).
More than 3 seconds starting from the visual diagnostics condition	Software diagnostics by means of optical interface and PC (hours of operation, malfunctions etc. can be viewed)

The sequence of pulses issued by the control box identifies the possible types of malfunction, which are listed in the table on pag. 26

SIGNAL	FAULT	PROBABLE CAUSE	SUGGESTED REMEDY
No blink	The burner does not start	1 - No electrical power supply . . . . . 2 - Limit control device TL is open. . . . . 3 - Safety control device TS is open . . . . . 4 - Control box lock-out . . . . . 5 - Pump is jammed . . . . . 6 - Erroneous electrical connections . . . . . 7 - Defective control box . . . . . 8 - Defective electrical motor. . . . .	Close all switches - Check fuses Adjust or replace Adjust or replace Reset control box (no sooner than 10 s after the lock-out) Replace Check Replace Replace
2 led blinks ● ●	After pre-purge and the safety time, the burner goes to lock-out and the flame does not appear	9 - No fuel in tank; water on tank bottom. . . . . 10 - Inappropriate head and air gate valve adjustments . . . . . 11 - Light oil solenoid valves fail to open . . . . . (1st stage or safety) 12 - 1st stage nozzle clogged, dirty, or deformed . . . . . 13 - Dirty or poorly adjusted firing electrodes . . . . . 14 - Grounded electrode due to broken insulation . . . . . 15 - High voltage cable defective or grounded . . . . . 16 - High voltage cable deformed by high temperature . . . . . 17 - Ignition transformer defective. . . . . 18 - Erroneous valves or transformer electrical connections 19 - Defective control box . . . . . 20 - Pump unprimed . . . . . 21 - Pump/motor coupling broken . . . . . 22 - Pump suction line connected to return line . . . . . 23 - Valves up-line from pump closed . . . . . 24 - Filters dirty: line - pump - nozzle . . . . . 25 - Defective photoresistor or control box . . . . . 26 - Photoresistor dirty . . . . . 27 - 1st stage operation of cylinder is faulty . . . . . 28 - Motor protection tripped . . . . . 29 - Defective motor command control device . . . . . 30 - 2-phase power supply thermal relay trips . . . . . 31 - Incorrect motor rotation direction . . . . .	Top up fuel level or suck up water Adjust, see pag. 14 and pag. 20 Check connections; replace coil Replace Adjust or clean Replace Replace Replace and protect Replace Check Replace Prime pump and see "Pump unprimed" Replace Correct connection Open Clean Replace photoresistor or control box Clean Change cylinder Reset thermal cut-out Replace Reset thermal cut-out when third phase is re-connected Change motor electrical connections
4 led blinks ● ● ● ●	The burner starts and then goes into lock-out	32 - Photoresistor short-circuit . . . . . 33 - Light is entering or flame is simulated . . . . .	Replace photoresistor Eliminate light or replace control box

SIGNAL	FAULT	PROBABLE CAUSE	SUGGESTED REMEDY
7 led blinks ● ● ● ● ● ● ●	Flame detachment	34 - Poorly adjusted head 35 - Poorly adjusted or dirty firing electrodes 36 - Poorly adjusted fan air gate: too much air 37 - 1st nozzle is too big (pulsation) 38 - 1st nozzle is too small (flame detachment) 39 - 1st nozzle dirty, or deformed 40 - Inappropriate pump pressure 41 - 1st stage nozzle unsuited to burner or boiler 42 - Defective 1st stage nozzle	Adjust, see pag. 14, Fig. 14 Adjust, see pag. 14, Fig. 10 or clean Adjust Reduce 1st nozzle delivery Increase 1st nozzle delivery Replace Adjust to between 10 - 14 bar See Nozzle Table, pag. 12 ; reduce 1st stage Replace
	The burner does not pass to 2nd stage	43 - Control device TR does not close 44 - Defective control box 45 - 2nd stage sol. valve coil defective 46 - Piston jammed in valve unit	Adjust or replace Replace Replace Replace entire unit
	Fuel passes to 2nd stage but air remains in 1st	47 - Low pump pressure 48 - 2nd stage operation of cylinder is faulty	Increase Change cylinder
	Burner stops at transition between 1st and 2nd stage or vice versa. Burner repeats starting cycle	49 - Nozzle dirty 50 - Photoresistor dirty 51 - Excess air	Replace Clean Reduce
	Uneven fuel supply	52 - Check if cause is in pump or in the fuel supply system	Feed the burner from a tank located nearby
	Rusty pump internal parts	53 - Water in tank	Suck water from tank bottom with separate pump
	Noisy pump, unstable pressure	54 - Air has entered the suction line. - Depression value too high (higher than 35 cm Hg) 55 - Tank/burner height difference too great 56 - Piping diameter too small 57 - Suction filters clogged 58 - Suction valves closed 59 - Paraffin solidified due to low temperature	Tighten connectors Feed burner with loop circuit Increase Clean Open Add additive to light oil
	Pump unprimes after prolonged pause	60 - Return pipe not immersed in fuel 61 - Air enters suction piping	Bring to same height as suction pipe Tighten connectors
	Pump leaks light oil	62 - Leakage from sealing organ	Replace pump
	Smoke in flame - dark Bacharach  - yellow Bacharach	63 - Not enough air 64 - Nozzle worn or dirty 65 - Nozzle filter clogged 66 - Erroneous pump pressure 67 - Flame stability spiral dirty, loose, or deformed 68 - Boiler room air vents insufficient 69 - Too much air	Adjust head and fan gate, see pag. 14 and pag. 20. Replace Clean or replace Adjust to between 10 - 14 bar Clean, tighten in place, or replace Increase Adjust head and fan gate, see pag. 14 and pag. 20.
	Dirty combustion head	70 - Nozzle or filter dirty 71 - Unsuitable nozzle delivery or angle 72 - Loose nozzle 73 - Impurities on flame stability spiral 74 - Erroneous head adjustment or not enough air 75 - Blast tube length unsuited to boiler	Replace See recommended nozzles, pag. 12 Tighten Clean Adjust, see pag. 20, open gate valve Contact boiler manufacturer
10 led blinks ● ● ● ● ● ● ● ● ● ●	The burner goes to lock-out	76 - Connection or internal fault 77 - Presence of electromagnetic disturbance	Use the radio disturbance protection kit

**10 STATUS (optional)**

Accessory available on request. See pag. 6.

**10.1 Assembly**

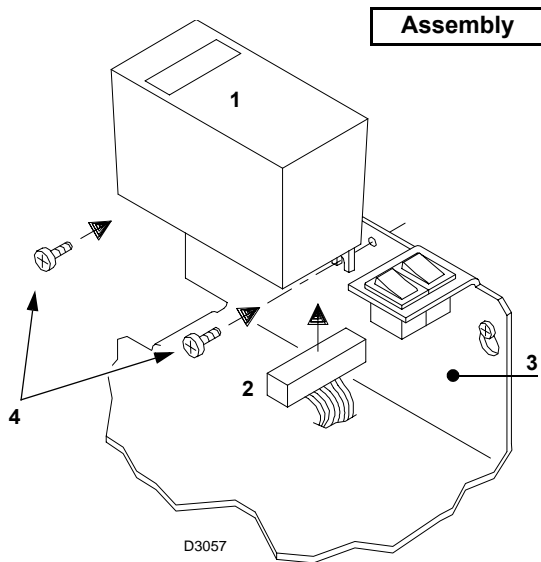

The burners are preset to accept the Status. To assemble, proceed as follows:

- Connect Status 1) using connector 2) fitted on the bracket 3).
- Fasten Status to the bracket using the screws 4) supplied with the kit.

- 1 Status
- 2 Connector
- 3 Bracket of the burner
- 4 Fixing screws

**Fig. 33**

**10.2 The STATUS unit has three functions:**

**1 Burner operating hours and the number of firings are shown on display V**

**Total operating hours**

Press button "h1".

**2nd stage operating hours**

Press button "h2".

**1st stage operating hours (calculated)**

Total hours - 2nd stage operating hours

**Number of firings**

Press button "count".

**Resetting operating hours and number of firings**

Press the three "reset" buttons simultaneously.

**Non-volatile memory**

The operating hours and the number of firings will remain in the memory even in the case of electrical power failures.

2 Indicates the times relative to the firing stage

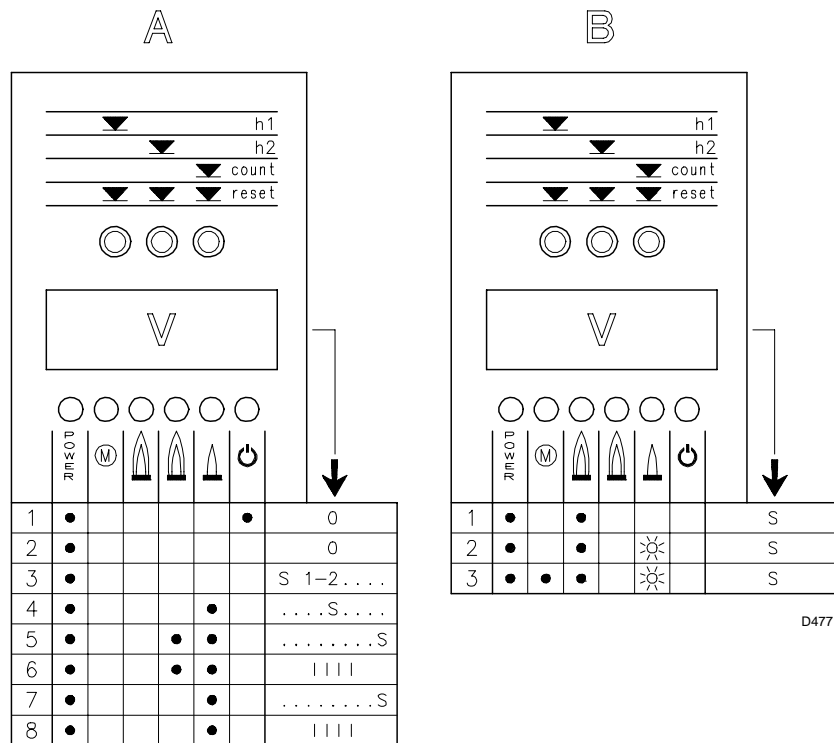

D477

- ☀ = LED flashing
- = LED illuminated
- S = Time in seconds
- |||| = Burner start cycle terminated

Fig. 34

The leds illuminate in the following sequence, see fig. A:

WITH CONTROL DEVICE TR CLOSED:

- 1 - Burner off, TL open
- 2 - Control device TL closed
- 3 - Motor start:  
seconds count starts on display V
- 4 - 1st stage valve energized
- 5 - 2nd stage valve energized  
seconds count stops on display V
- 6 - 10 seconds after stage 5 the code |||| will appear on the display: this indicates that the starting phase is terminated.

WITH CONTROL DEVICE TR OPEN:

- 1 - Burner off, TL open
- 2 - Control device TL closed
- 3 - Motor start:  
seconds count starts on display V
- 4 - 1st stage valve energized
- 7 - 30 seconds after stage 4:  
seconds count stops on display V
- 8 - 10 seconds after stage 7 the code |||| will appear on the display: this indicates that the starting phase is terminated.

The times, in seconds, shown on display V, indicate the succession of the various starting stages described on pag. 22

3 In the case of burner malfunctions, the status panel indicates the exact time at which the fault occurred.

There are 3 possible combinations of illuminated leds, see fig. (B).

For the causes of the malfunction refer to the numbers shown in brackets; see the legend on pag. 26 for interpretation of the numbers.

- 1..... (9 ÷ 10)
- 2..... (11 ÷ 33)
- 3..... (32)

Key to symbols (STATUS)

- POWER = Power present
- (M) = Fan motor blocked (red)
- (flame) = Burner lock-out (red)
- (flame) = 2st stage operation
- (flame) = 1st stage operation
- (power) = Load level reached (Stand-by), led: on

D478





<b>1</b>	<b>声明</b>	<b>2</b>
<b>2</b>	<b>总则</b>	<b>3</b>
2.1	说明书相关信息	3
2.2	承诺与责任	4
<b>3</b>	<b>安全与防护</b>	<b>5</b>
3.1	介绍	5
3.2	人员培训	5
<b>4</b>	<b>燃烧器技术描述</b>	<b>6</b>
4.1	技术数据	6
4.2	燃烧器描述 (图 1)	7
4.3	出力范围 (图 3)	9
<b>5</b>	<b>安装</b>	<b>10</b>
5.1	悬挂	10
5.2	初步检查	10
5.3	锅炉法兰 (图 6)	11
5.4	燃烧筒长度 (图 7)	11
5.5	固定燃烧器到锅炉上 (图 8)	11
5.6	一段火及二段火喷嘴选择	12
5.7	喷嘴安装	13
5.8	燃烧头设置	14
<b>6</b>	<b>电气系统</b>	<b>15</b>
6.1	电气系统 (工厂设定)	16
<b>7</b>	<b>管路系统</b>	<b>18</b>
7.1	燃油供应	18
7.2	油路连接 (图 20)	19
7.3	油泵 (图 21)	19
<b>8</b>	<b>燃烧器校准</b>	<b>20</b>
8.1	点火	20
8.2	运行	20
<b>9</b>	<b>维护</b>	<b>23</b>
9.1	燃烧器启动阶段故障诊断	25
9.2	复位控制盒及执行故障诊断	25
9.3	复位控制盒	25
9.4	可视诊断	25
9.5	软件诊断	26
<b>10</b>	<b>状态显示面板 (可选)</b>	<b>28</b>
10.1	组装	28
10.2	“状态显示面板”具有以下三个功能:	28

## 1 声明

## 本产品符合 ISO / IEC 17050-1 标准

制造商：	RIELLO S.p.A.		
地址：	Via Pilade Riello, 7 37045 Legnago (VR)		
产品：	轻油燃烧器		
型号：	RL 70 RL 100 RL 130		
产品符合以下技术标准：	EN 267 EN 12100		
并且遵循欧洲标准：			
MD	2006/42/EC	机械标准	
LVD	2006/95/EC	低电压标准	
EMC	2004/108/EC	电磁兼容性	

产品质量得到 UNI EN ISO 9001 认证组织许可。

## 制造商声明

RIELLO S.p.A. 声明以下产品遵守德国颁布的 NOx 排放限制标准“1. BImSchV release 26.01.2010”。

产品	类型	型号	功率
轻油燃烧器	661 T1	RL 100	356 - 1186 kW
	662 T1	RL 130	486 - 1540 kW

Legnago, 15.03.2010

G. Conticini 先生  
燃烧器分部  
RIELLO S.p.A.



2 总则

2.1 说明书相关信息

介绍

说明书随燃烧器一起提供：

- 说明书是产品不可缺少的组成部分，不得将其与产品分离。因此必须认真保存以便查阅，若燃烧器转至其他所有人或使用人，则说明书必须随之一同移交。若说明书遗失或损毁，则可从就近 **RIELLO** 技术支持中心索取说明书复印件；
- 专为有资质的操作人员编写；
- 说明书包括关燃烧器的安全安装、启动、使用、维护等重要操作的说明。

标志使用

在说明书的某些部分将看到带有三角危险标志。请特别关注这些标志，因其指出了某些潜在危险场合。

2.1.1 通常危险

这些危险分为 3 个等级，显示如下。



最危险等级！  
此标志针对那些导致严重受伤、死亡或长期健康风险的非正确操作。



此标志针对那些可能导致严重受伤、死亡或长期健康风险的非正确操作。



此标志针对那些可能导致机器损坏并且 / 或者对人伤害的非正确操作。

2.1.2 危险：带电部件



此标志针对那些导致致命电击的非正确操作。

其他标志



环境保护

此标志对使用机器时涉及到环境保护因素给出提示。

- 此标记如下表所示。

缩写使用

Ch.	章
Fig.	图
Pag.	页
Sec.	段
Tab.	表

设备和说明书的转移

当设备转移时，重要提示：

- 说明书应由设备制造商提供给用户，并推荐将其置于装有加热设备的室内。
- 说明书可显示：  
燃烧器序列号；  
最近援助中心的地址和电话号码；
- 设备提供商应告知用户：
  - 设备的使用方法，
  - 在设备启动前任何必要的测试，
  - 设备维护及每年至少一次由制造商或其他专业技术人员实施的全面检查。
 为确保周期性的检查，**RIELLO** 建议签订一份维护保养合同。

## 2.2 承诺与责任

**RIELLO** 根据现行法律或销售合同，从安装之日起 Riello 承诺对其产品保修。在初次启用之时，检查燃烧器是否完备。



警告

未遵守本手册的违规行为、操作疏忽、错误安装和擅自改装将导致 **RIELLO** 保修承诺失效。

特别是由于以下所述原因引起的人身伤害，保修的权益和义务是失效的：

- 非正确安装、启动、使用和维护燃烧器；
- 不适当、不正确或不合理使用燃烧器；
- 不具备资格人员的操作使用；
- 未经授权对设备的改装；
- 与失效、非正确应用或未认证的安全仪器用于燃烧器；
- 在燃烧器上安装未经测试的部件；
- 用不适当的燃料燃烧；
- 燃料供应系统出错；
- 在提示错误或不规范的情况下仍然使用燃烧器；
- 局部或整机非正确维修；
- 对于燃烧室的改造以致阻碍火焰正常喷射；
- 对燃烧器内易磨损、开裂的部件管理疏漏；
- 非原装 **RIELLO** 部件的使用，包括备用零件、成套部件、附件和可选件；
- 不可抗拒的外界因素。

此外 **RIELLO** 拒绝承担未遵守本手册而造成不良后果的责任。

## 3 安全与防护

### 3.1 介绍

**RIELLO** 燃烧器按照当前规章标准设计制造，应用了已知的安全技术并考虑了可预见的潜在危险情况。

当然，草率而错误的使用设备将导致对操作者或第三方死亡的情形，以及对燃烧器或其他设备的损坏。特别是缺乏慎重和盲目自信通常导致事故；疲劳和乏困亦将如此。

记住：

- 燃烧器必须只能按照说明书中所描述的使用。任何其他使用操作将被视为不适当的和危险的。  
特别是：  
燃烧器只能应用于热水锅炉、蒸汽锅炉、导热油炉及其他制造商特意注明的使用场所；  
燃料的类型和压力，电源的电压和频率，燃烧器可调的最大和最小出力均应在控制范围内，炉膛压力、炉膛尺寸和室温必须和说明书上的标识相符。
- 不允许改造燃烧器以变更其性能和用途。
- 燃烧器必须在通用的技术安全条件下使用。与安全相违的任何干扰应立即排除。
- 除非零件维修，不允许拆开或替换燃烧器部件。
- 只有符合制造商声明的零件可以替换。

### 3.2 人员培训

用户是指已获得机器并打算用于某种特定目的的个人、团体或公司。用户应对机器负责并有义务对燃烧器操作和使用的人员进行培训。

用户：

- 承诺将机器完整地托付给受过适当培训和有资格的人员；
- 必须采取各种必要的措施以避免未经授权的人员接近机器；
- 承诺告知过其工作人员对安全规则的应用和遵守。并以此为目的，用户应确保每个工作人员了解其用途和自身责任范围内的安全细则；
- 必须通知制造商所观察到的事故预防系统故障，以及任何可预见的危险情况。
- 工作人员必须始终使用安全防护设备并且遵守手册中给出的提示。
- 工作人员必须遵守所有机器显示的警告和警告提示。
- 工作人员不准个人决定在其管辖之外的执行操作或干预。
- 工作人员应当对各种可能出现的问题和危险情况通知其上级。
- 用其他厂商制造的零件装配或修改可能改变机器特性并因此与安全操作相违背。因此，由于使用非原装零件而造成的任何危害，制造商拒绝承担任何责任。

## 4 燃烧器技术描述

## 4.1 技术数据

型号		RL 70	RL 100	RL 130	
类型		660 T1	661 T1	662 T1	
热功率 (1) 出力 (1)	两段火	kW	474 - 830	711 - 1186	948 - 1540
		Mcal/h	408 - 714	612 - 1020	816 - 1325
		kg/h	40 - 70	60 - 100	80 - 130
	一段火	kW	255 - 474	356 - 711	486 - 948
		Mcal/h	219 - 408	306 - 612	418 - 816
		kg/h	21.5 - 40	30 - 60	41 - 80
燃料		轻油			
- 净热值		kWh/kg	11.8		
		Mcal/kg	10.2 (10.200 Kcal/kg)		
- 密度		kg/dm <sup>3</sup>	0.82 - 0.85		
- 在 20 °C 时粘度		最大 mm <sup>2</sup> /s	6 (1,5 °E - 6 cSt)		
运行		间歇式运行 (24 小时至少 1 次暂停) 两段火 (高低火) 和单段火			
喷嘴		数量	2		
标准应用		锅炉: 热水炉、蒸汽炉、导热油炉			
环境温度		°C	0 - 40		
助燃空气温度		最大 °C	60		
电源		V	230 - 400V 带零线 ~ +/- 10%		
		Hz	50Hz - 三相		
电机		rpm	2800	2800	2800
		W	1100	1500	2200
		V	220/240 - 380/415	220/240 - 380/415	220/240 - 380/415
		A	4.7 - 2.7	6.4 - 3.7	8.5 - 4.9
点火变压器		V1 - V2	230 V - 2 x 5 kV		
		I1 - I2	1.9 A - 30 mA		
油泵	出力 (在 12 bar 时)	kg/h	107	220	220
	压力范围	bar	10 - 20	10 - 20	10 - 20
	燃油温度	最大 °C	60	60	60
电功率消耗		最大 W	1400	1800	2600
电气保护等级		IP 44			
符合 EEC 标准		2004/108 - 2006/95 - 2006/42			
噪声水平 (2)		dBA	75	77	78.5

(1) 参考条件: 环境温度 20 °C - 大气压力 1000 mbar - 海拔 100 m a.s.l.

(2) 噪声值于制造商的燃烧实验室内测得, 且燃烧器处于最大额定出力状态。

## 4.1.1 可选型号

型号	编码	电源	燃烧筒长度 mm
RL 70	20042311	三相	250
RL 100	20042308	三相	250
RL 130	20042309	三相	250

## • 电磁干扰保护装置

如果由于装有变频器, 使得燃烧器易受电磁干扰 (电磁信号强度超过 10 V/m), 或恒温器的连接线长度超过 20 米, 需要在电气控制与燃烧器之间加装电磁干扰保护装置。

燃烧器	RL 70 - RL 100 - RL 130
编码	3010386

## 4.1.2 附件 (可选):

- 状态显示面板 (参见第 29 页): 编码 3010322

**油气分离装置**

空气可能随轻油一起被吸入油泵。这些空气可能由于负压或密封不良而存在于轻油中。

在双管系统中，空气可经回油管回到油箱中；在单管系统中，空气仍存在于油路循环系统中，会引起油泵压力变化及燃烧器故障。

因此，我们建议在安装单管系统时，为燃烧器安装一个油气分离装置。

油气分离装置有以下两种型号可提供：

编码 **3010054** 不带过滤器

编码 **3010055** 带过滤器

- 燃烧器出力 : 最大 80 kg/h
- 轻油压 : 最大 0.7 bar
- 环境温度 : 最大 50 °C (不带过滤器)
- 环境温度 : 最大 40 °C (带过滤器)
- 轻油温度 : 最大 50 °C (不带过滤器)
- 轻油温度 : 最大 40 °C (带过滤器)
- 附件连接接口 : 1/4 英寸

对于出力大于 80 kg/h 的燃烧器，安装两个并联的油气分离装置。

**4.2 燃烧器描述 (图 1)**

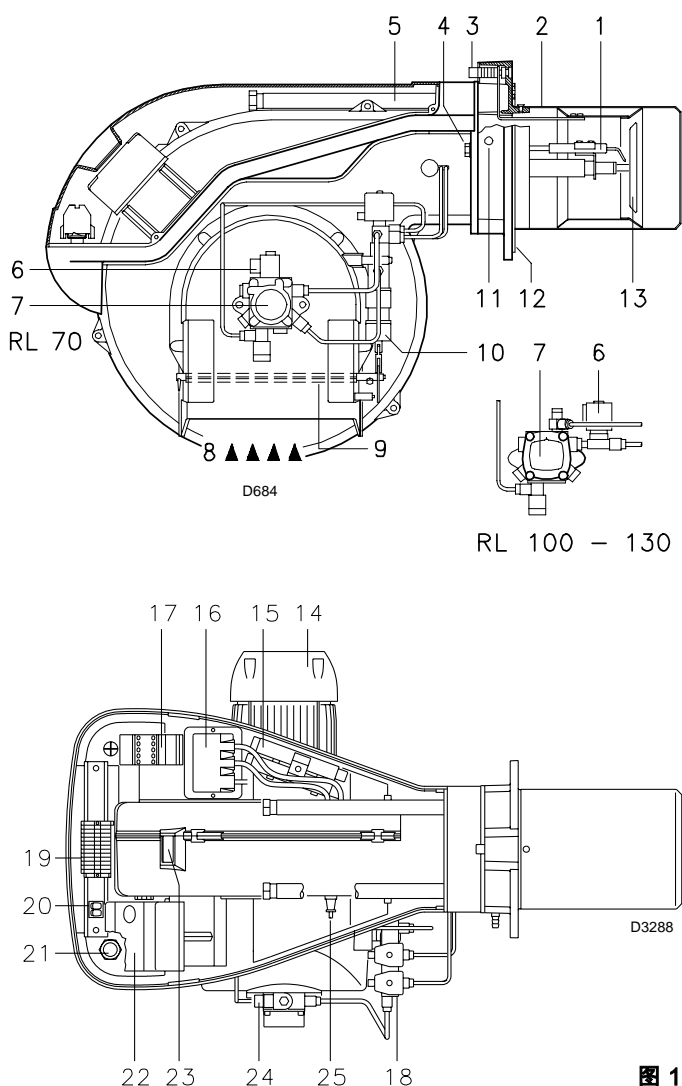

- 1 点火电极
- 2 燃烧头
- 3 燃烧头调节螺栓
- 4 固定风机到法兰用螺栓
- 5 打开燃烧器和检查燃烧头用滑杆
- 6 安全电磁阀
- 7 油泵
- 8 风机进风口
- 9 风量挡板
- 10 一段火和二段火运行风量挡板调节用液压缸。燃烧器停机时，风量挡板完全关闭，以降低因通风造成空气从风机吸入口进入而产生的锅炉热量散发。
- 11 风机压力测试点
- 12 连接锅炉用法兰
- 13 稳焰盘
- 14 电机
- 15 滑杆加长杆 5)
- 16 点火变压器
- 17 电机接触器和带复位按钮的热继电器
- 18 一段火及二段火电磁阀
- 19 接线端子板
- 20 两组开关：  
- 之一为“燃烧器关闭 - 启动”  
- 之二为“一段火 - 二段火”运行转换开关
- 21 由安装人员负责接线的导缆孔
- 22 带锁定指示灯和锁定复位按钮的控制盒
- 23 火焰观察孔
- 24 油泵压力调节钮
- 25 火焰监测电眼

两种燃烧器故障：

**控制盒锁定：**如果控制盒 22) 按钮 (图 1) (红色 LED 灯) 灯亮起，则表明燃烧器已被锁定。若要复位，按住该按钮 1-3 秒。

**电机锁定：**按下热继电器按钮 17) (图 1) 以恢复供电。

图 1

**4.2.1 重量 (表 A) - 大概值**

- 燃烧器的重量包括其包装的完整重量见表 (表 A)。

	kg
RL 70	60
RL 100	63
RL 130	66

表 A

### 4.2.2 最大尺寸 (图 2) - 大概值

燃烧器最大尺寸见 (图 2) 所示。

注意检查燃烧头时需要打开燃烧器，将其后部沿滑杆拉出。打开后燃烧器的尺寸已在 I 位置上标出。



图 2

mm	A	B	C	D	E	F	G	H	I
RL 70	580	296	284	555	680	250	179	430	951
RL 100	599	312	287	555	680	250	179	430	951
RL 130	625	338	287	555	680	250	189	430	951

### 4.2.3 标准配置

- 2 - 软管
- 2 - 软管垫圈
- 2 - 软管接头
- 1 - 隔热垫
- 2 滑杆 5)(图 1) 的加长杆 15)(图 1)  
(针对燃烧筒长度为 385 mm)
- 4 - 固定燃烧器法兰到锅炉上的螺栓 : M 12 x 35
- 2 - 喷油嘴
- 1 - 指导说明书
- 1 - 配件清单

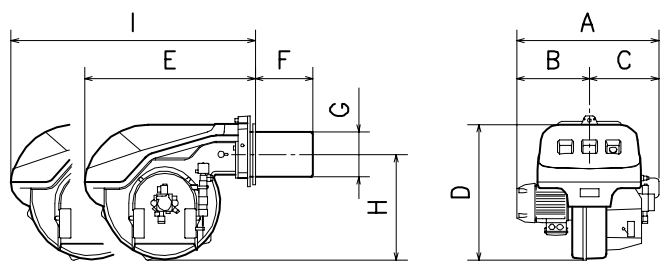

4.3 出力范围 (图 3)



图 3



图 4

RL 70 - 100 - 130 型号燃烧器有两种工作模式: 单段火和二段火。

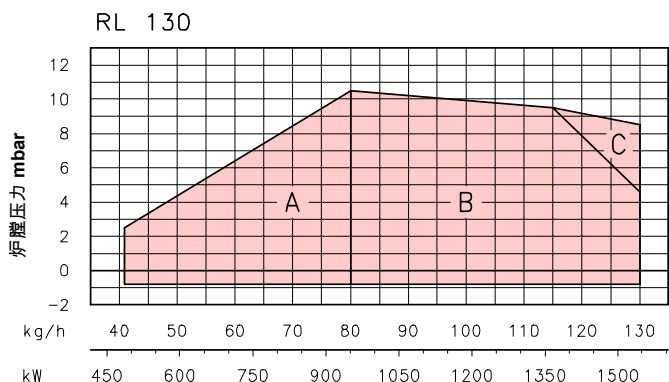
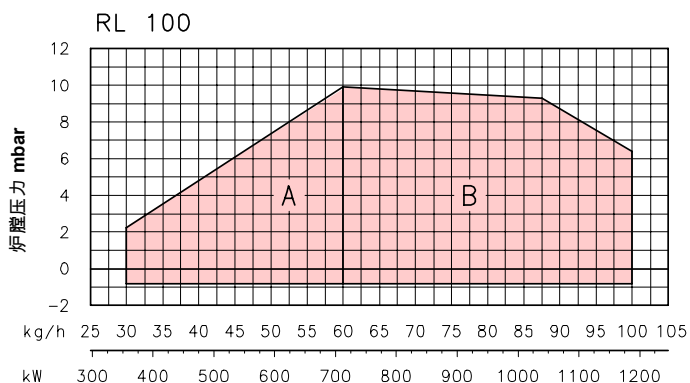
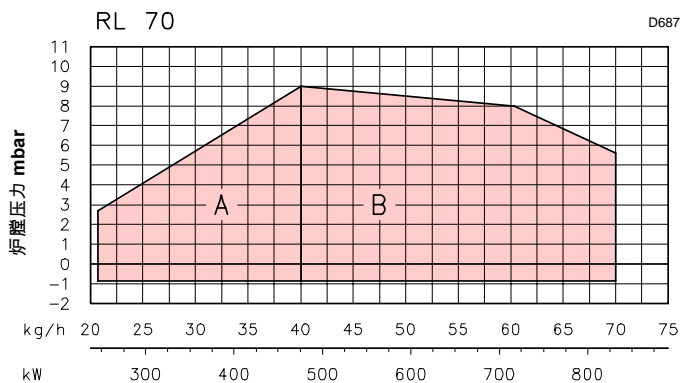
**一段火出力** 范围必须在左图所示 A 区内选择。

**二段火出力** 范围必须在左图所示 B 区内选择 (RL130 对应 C 区)。根据炉膛内背压, 此为燃烧器所供的最大出力。

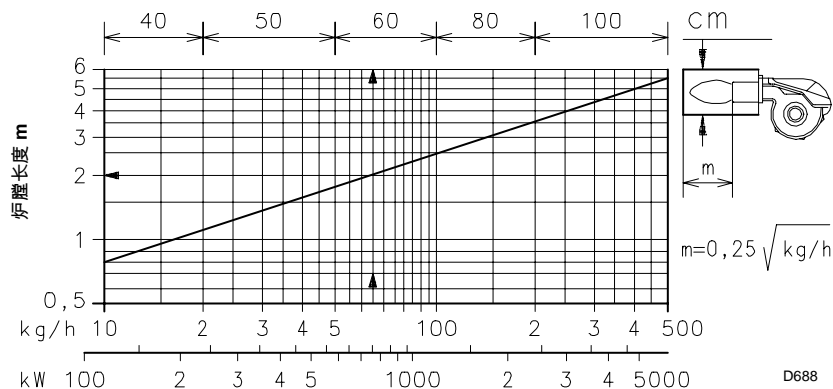
从期望得到的燃烧器出力处画一条垂直线, 从炉膛背压处画一条水平线, 两线交点即为燃烧器工作点。此点必须位于 B 区内。

为达到工作区域 B (对 RL130 而言达到 C 区), 有必要按第 11 页所述校准燃烧头。



出力曲线的出力值在如下条件获得: 环境温度 20 °C, 大气压 1000 mbar (约 100 m 海拔), 燃烧头按第 14 页所示调整。

警告

4.3.1 测试锅炉 (图 4)

出力曲线是根据 EN 267 标准在专用试验锅炉上进行测试绘制而成的。

图 4 给出试验锅炉炉膛直径和长度。

**举例:**

出力 65 kg/ 小时

直径 = 60 cm ; 长度 = 2 m。

若燃烧器安装于尺寸特别小的商用锅炉炉膛时, 需进行预试验。

## 5 安装

### 安全安装注意事项

清理干净安装燃烧器的区域，排布好正确的环境照明，然后进行安装作业。



危险

在燃烧器的安装，维护和拆解操作时必须切断电源。



警告

燃烧器的安装必须由专业人员来操作。并根据手册说明，遵守标准和现行的法律法规来进行。

### 5.1 悬挂

燃烧器的包装包括有一个木托架，因此可以用吊装卡车或叉车随燃烧器一起搬动（同燃烧器一起被打包）。



警告

如果燃烧器在悬挂作业时没有引起重视将是相当危险的：让无关人员撤离的足够远；并检查悬挂是可靠的和合理的。检查工作区域是空旷的，并且有安全区域（假设燃烧器发生坠落，可以让人快速逃离至安全区域）。

悬挂的时候，确保离地面不超过 20-25 cm。



小心

在燃烧器在安装点定位之后，迅速清除剩余所有包装，将各种不同的材料分开。在开始安装操作之前，应当仔细清理干净安装燃烧器的所有区域。

### 5.2 初步检查

#### 检查货物



小心

在拆除包装后，检查货物完整无缺。如有疑问，不要使用燃烧器，并和供应商取得联系。



包装材料（木托架或纸箱、钉子、夹子、塑料袋等等）不要随意丢弃，因为会有潜在危险和污染；它们应当被收集起来并在适当的地方被处置。

#### 检查燃烧器的特性

► 燃烧器最小和最大的出力数据 (G) (见出力表)

R.B.L.	A		G	
B	C	G		
D	E			
F				
RIELLO S.p.A. I-37045 Legnago (VR)				

图 5



警告

燃烧器热功率必须在锅炉出力范围之内；



警告

燃烧器标签如被篡改、脱落或丢失将导致无法识别燃烧器，使得安装和维护工作变得困难。

检查燃烧器的识别标签，如下所示：

- 燃烧器型号 (A 见图 5) 和类型 (B)；
- 制造年份 (C)；
- 序列号 (D)；
- 电源输入功率 (E)；
- 使用的燃料型号和相应的供给压力 (F)；

### 5.3 锅炉法兰 (图 6)



图 6

按图 (6) 所示在锅炉上钻固定孔。

钻孔位置可以用随机带的隔热垫划线标记。

mm	A	B	C
RL 70	185	275-325	M 12
RL 100	185	275-325	M 12
RL 130	195	275-325	M 12

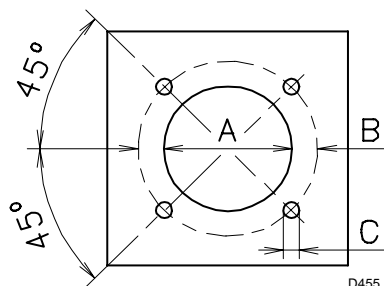
### 5.4 燃烧筒长度 (图 7)



图 7

燃烧筒的长度必须根据锅炉制造商所提供的说明书来选择, 并且在任何情况下必须大于锅炉前炉墙和炉衬的总厚度。

燃烧筒 9): RL 70 RL 100 RL 130  
L = mm 250 250 250

对于带前烟箱 12) 或反转火焰的锅炉, 必须在护衬 11) 及燃烧筒 9) 之间插入耐火材料制作的防护炉衬 10)。

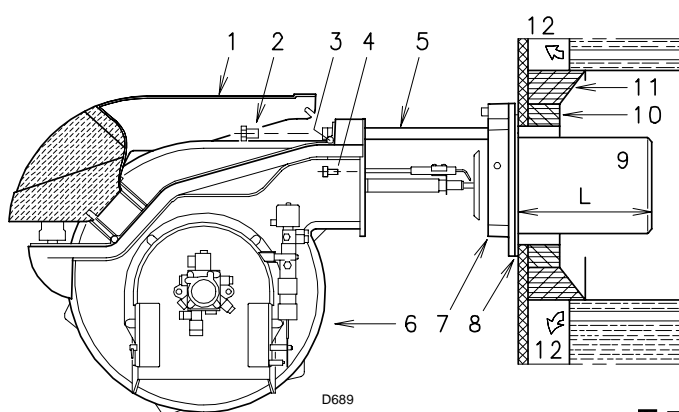
防护炉衬不能妨碍燃烧筒的移动。

对于有前水冷壁的锅炉炉衬 10)-11) (图 7) 可以省略, 除非锅炉厂商特别要求。

### 5.5 固定燃烧器到锅炉上 (图 8)



图 8

按如下步骤, 从燃烧器 6) 拆下燃烧筒 9):

- 松掉四个螺栓 3) 取下盖板 1)。
- 拆掉两个滑杆 5) 上的螺栓 2)。
- 拆下固定燃烧器 6) 到法兰 7) 上螺栓 4)。
- 将燃烧筒 9)、法兰 7)、滑杆 5) 全部拉出。

燃烧器和锅炉之间的密封必须达到气密标准。

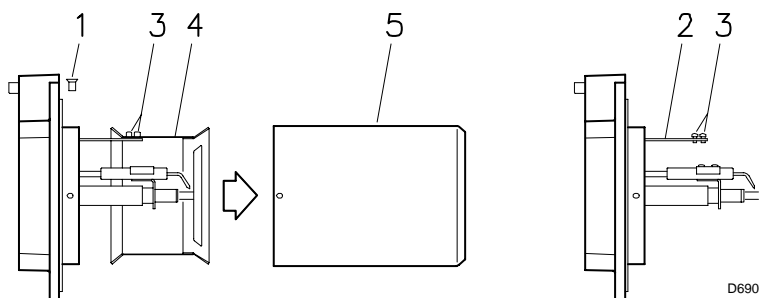
#### 燃烧头校准

对于型号 RL 130 燃烧头的校准, 此时需检查燃烧器二段火时的最大出力是否位于出力范围的 B 区或 C 区。参见第 9 页。

如果出力位于 B 区, 则无需进行任何校准。

但如果出力位于 C 区, 则:

- 拧下螺栓 1) (图 8), 并拆下燃烧筒 5)
- 拧下螺栓 3) 并移动内套筒 4)
- 拧紧调节杆 2) 上的螺栓 3)
- 现在重装燃烧筒 5) 和螺栓 1)

一旦进行上述操作 (若必要), 固定法兰 7) (图 7) 到锅炉法兰上, 两者间插入随附的密封垫 8)。

随机提供了 4 个螺栓, 需使用防磨损产品 (高温油脂、化合物、石墨) 保护螺栓螺纹后再使用它们。

## 5.6 一段火及二段火喷嘴选择

两个喷嘴都必须从表 (B) 中选出。

**1号喷嘴**决定一段火时燃烧器的流量。

**2号喷嘴**与1号喷嘴同时工作，决定了二段火时燃烧器的流量。

一段火和二段火流量必须在第6页所示数值范围之内。

建议压力在12 bar时，喷嘴喷射角度为60°。

两个喷嘴通常具有相等的流量，但也可根据需要对1号喷嘴进行如下调节：

- 当点火时，需要降低背压峰值，此时流量应小于总流量的50%（在一段火和二段火时，燃烧器流量应在40 - 100%之间，以保证良好的燃烧效率）。
- 当一段火运行时，需要提高燃烧效率，此时流量应大于总流量的50%。

**举例** 型号 RL 70：

锅炉功率 = 635kW - 效率 90 %

燃烧器所需出力 =

635 : 0,9 = 705 kW

705 : 2 = 352 kW 每一喷嘴；

因此，所需两个喷嘴相同，喷射角度60°，油压12 bar：

1° = 7,0 GPH - 2° = 7,0 GPH,

或以下两个不同喷嘴：

1° = 6,0 GPH - 2° = 8,0 GPH,

或：

1° = 8,0 GPH - 2° = 6,0 GPH,

GPH	kg/h (1)			kW 12 bar
	10 bar	12 bar	14 bar	
5.00	19.2	21.2	23.1	251.4
5.50	21.1	23.3	25.4	276.3
6.00	23.1	25.5	27.7	302.4
6.50	25.0	27.6	30.0	327.3
7.00	26.9	29.7	32.3	352.3
7.50	28.8	31.8	34.6	377.2
8.00	30.8	33.9	36.9	402.1
8.30	31.9	35.2	38.3	417.5
8.50	32.7	36.1	39.2	428.2
9.00	34.6	38.2	41.5	453.1
9.50	36.5	40.3	43.8	478.0
10.0	38.4	42.4	46.1	502.9
10.5	40.4	44.6	48.4	529.0
11.0	42.3	46.7	50.7	553.9
12.0	46.1	50.9	55.3	603.7
12.3	47.3	52.2	56.7	619.1
13.0	50.0	55.1	59.9	653.5
13.8	53.1	58.5	63.3	693.8
14.0	53.8	59.4	64.5	704.5
15.0	57.7	63.6	69.2	754.3
15.3	58.8	64.9	70.5	769.7
16.0	61.5	67.9	73.8	805.3
17.0	65.4	72.1	78.4	855.1
17.5	67.3	74.2	80.7	880.0
18.0	69.2	76.4	83.0	906.1
19.0	73.0	80.6	87.6	956.0
19.5	75	82.7	89.9	980.9
20.0	76.9	84.8	92.2	1005.8
21.5	82.7	91.2	99.1	1081.7
22.0	84.6	93.3	101.4	1106.6

表 B

(1) 轻油：密度 0.84 kg/dm<sup>3</sup> - 粘度 4.2 cSt/20 °C - 温度 10 °C

5.7 喷嘴安装



图 9

在安装的这一阶段，燃烧器和燃烧筒还未安装到一起，因此可以在取下塑料塞子 2)(图 9)后，用 16 mm 扳手 1)(图 9)将两个喷嘴从稳焰盘的中心进行安装。请勿使用任何密封材料，如密封垫、复合密封材料或密封胶带。注意不要损坏喷嘴的密封座。安装时必须将喷嘴拧到位，但不要拧脱扣。

一段火的喷嘴位于点火电极下，如图 10) 所示。

请确认点火电极连接位置如图 10) 所示。

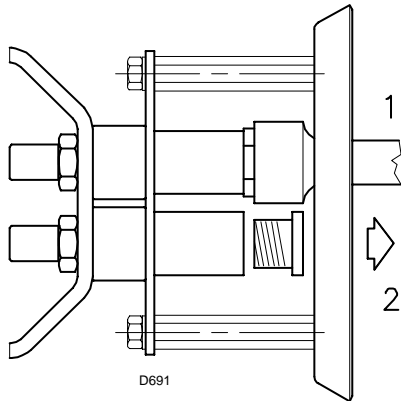
最后将燃烧器 3)(图 11) 重新安装到滑杆 2) 上，并将其一直推到法兰 5) 处，滑动时将燃烧器轻微托起，避免稳焰盘与燃烧筒发生摩擦。

拧紧滑杆 2) 上的螺栓 1) 和螺栓 4) 使燃烧器和法兰密封。

如确需为已安装到锅炉上的燃烧器更换喷嘴，则需按以下提示步骤操作：

- 按第 11 页图 (7) 所示，将燃烧器沿滑杆取下。
- 取下螺母 1) (图 12) 和稳焰盘 2)。
- 使用扳手 3)(图 12) 更换喷嘴。



图 10

NOTE:

只有在符合流量要求时才能使用随附的喷嘴。否则需用符合要求的喷嘴来替换。

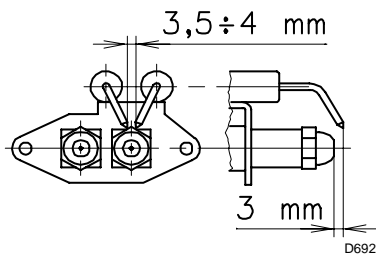

图 11



图 12

**5.8 燃烧头设置**

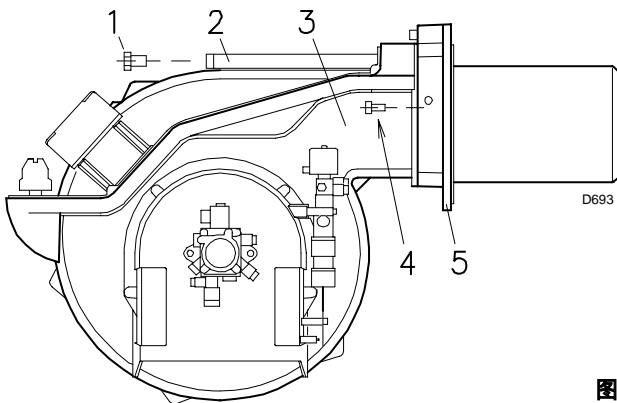

**图 13**

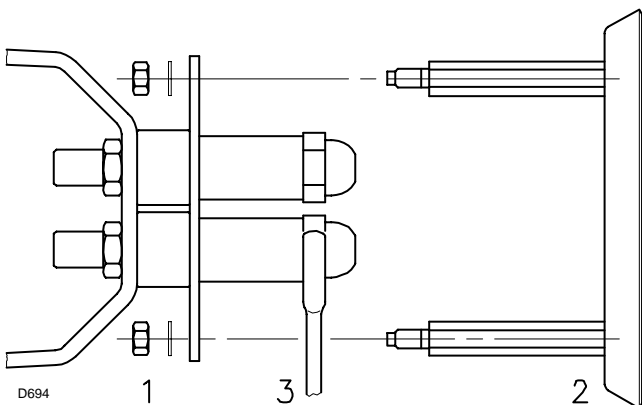
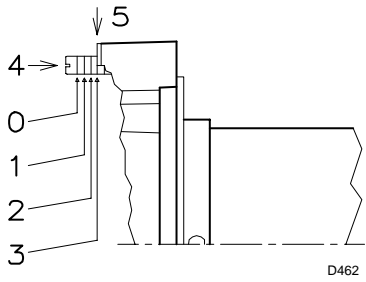
燃烧头的设置完全取决于燃烧器二段火的出力，即从第 12 页给出范围内选择的两个喷嘴的总流量。

旋转螺栓 4)( 图 13) 直至指示杆上的刻槽 ( 图 14) 与法兰 5( 图 13) 的表面对齐。

**举例：**

RL 70 机型配两个 6.0GPH 喷嘴以及 12 bar 油泵压力。

两个 6.0 GPH 喷嘴的流量见表 (B, 第 12 页)：

$25.5 + 25.5 = 51 \text{ kg/h.}$

图 14) 显示，在流量为 51 kg/h 时，燃烧器 RL 70 需要将其燃烧头调整至刻度“3”，如图 13 所示。

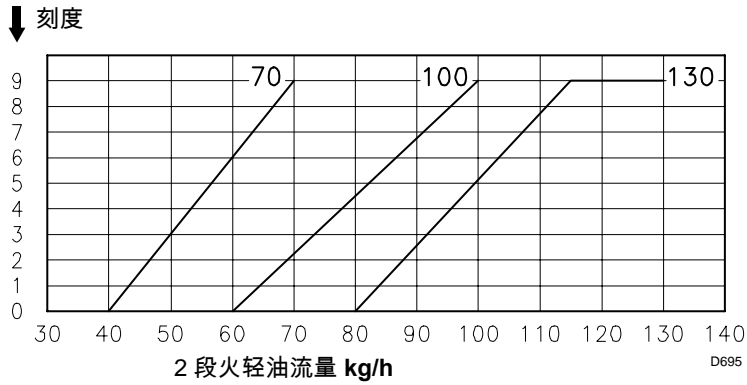

**图 14**

## 6 电气系统

### 电气接线的安全注意事项



危险

- 在电气接线时必须要求断开电源。
- 电气接线必须由合格人员进行操作，并遵守现行的法律法规。参考接线图。
- **RIELLO** 拒绝承担责任，由于修改或没有根据电气接线图的连接所造成的后果。
- 不要接反电力供应线，任何接线错误都会引起点火失败而将燃烧器锁定。
- 燃烧器 RL 70-100-130 为间歇性操作类型。这意味着燃烧器至少每 24 小时内强制停机一次，使控制盒进行自身启动效率的检查。通常情况下，锅炉的恒温器 / 压力开关也会保证燃烧器的停机。  
如果没有这样的条件，可以在系统中安装一个时间开关至 IN 中来提供至少每 24 小时内强制停机一次的指令。参照接线图。
- 根据现行标准，设备的电气安全取决于其需要正确连接到有效的接地系统。有必要检查此最基本的安全要求。在有疑问的情况下，由合格人员检查电气系统。
- 就如标签和手册上标识的一样，电气系统必须符合设备的最大输入功率，特别要检查一下电缆截面是否符合设备输入功率。
- 对设备的主电源供应：
  - 不要使用适配器，多头插座或私自拉线；
  - 使用一个全开后距离触点至少有 3 mm 的单级开关（过压型），如现行安全标准表述的那样。
- 不要用湿的或潮湿的身体部位或赤脚触碰设备。
- 不要拉扯电缆。

6.1 电气系统 (工厂设定)



图 15

燃烧器 RL 70 - RL 100 - RL 130

- ▶ RL 70 - 100 - 130 型燃烧器，工厂预设 400 V 电源。
- ▶ 如果使用 230 V 电源，将电机连接由星型改为三角形，同时改变热继电器的设置。

图示 (图 15)

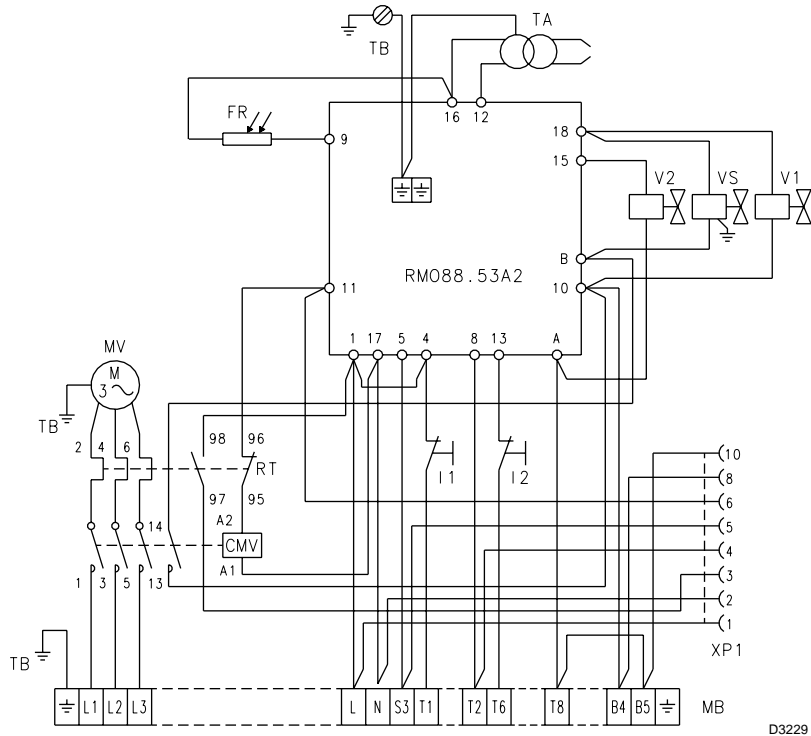
- CMV - 电机接触器
- FR - 光敏电阻
- I1 - 开关：燃烧器关闭 - 启动
- I2 - 开关：1 段火 - 2 段火转换开关
- MB - 接线端子
- MV - 风机电机
- RM088.53A2 - 控制盒
- RT - 热断路器
- TA - 点火变压器
- TB - 燃烧器接地连接
- V1 - 1 段火电磁阀
- V2 - 2 段火电磁阀
- VS - 安全电磁阀
- XP1 - “状态显示面板”连接

NOTE:

要使用远程复位，将按钮开关 (NO) 与控制盒接线端子 3 及零线间的任意端子 (接线端子 15, 16, 17 和 18) 连接。

6.1.1 电气连接 (图 16)



图 16

由安装方负责

根据 EN 60 335-1 标准使用柔性电缆：

- ▶ 如使用 PVC 套管，电缆最低标准为 H05 VV-F。
- ▶ 如使用橡胶套管，电缆最低标准为 H05 RR-F。

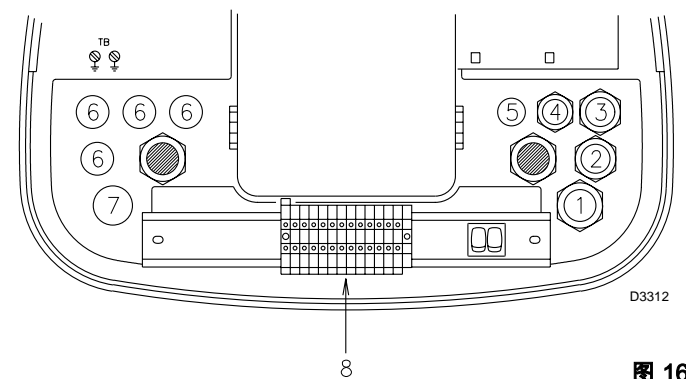
所有连接到燃烧器插座 8) (图 16) 的电缆必须穿过导缆孔。

导缆孔和备用孔可用于不同的方式。例如：

- 1 Pg 13,5 三相电源
- 2 Pg 11 单相电源
- 3 Pg 11 控制装置 TL
- 4 Pg 9 控制装置 TR
- 5 Pg 9 备用导缆孔
- 6 Pg 11 备用导缆孔
- 7 Pg 13,5 备用导缆孔



RL 70 - 100 - 130 型燃烧器电气连接，三相 230/400 V 电源，带零线和相线



图 17

		RL 70		RL 100		RL 130	
		230 V	400 V	230 V	400 V	230 V	400 V
F	A	T10	T6	T16	T10	T16	T10
L	mm <sup>2</sup>	1.5	1.5	1.5	1.5	1.5	1.5

导线截面积见表 (17)

电缆截面积未标示：1.5 mm<sup>2</sup>。

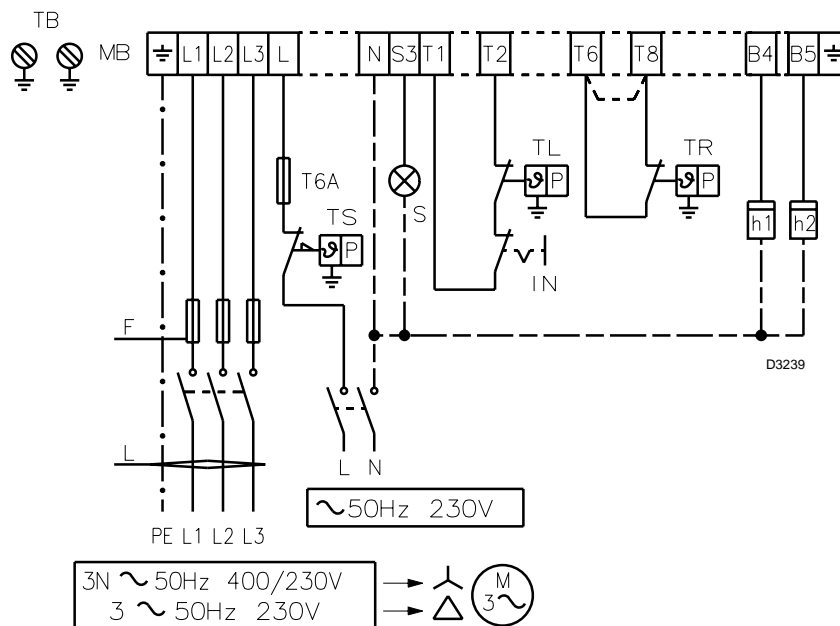
电气接线图示 (图 17)

- H1 - 1 段火计时器
- H2 - 2 段火计时器
- IN - 燃烧器手动停止开关
- MB - 接线端子板
- S - 远程锁定信号
- TB - 燃烧器接地连接
- TL - 限位装置：此限位装置在锅炉温度或压力超过预设值时将燃烧器停机。
- TR - 高-低火模式控制系统：此系统用来控制1段火和2段火，且仅在两段火运行模式下启动。
- TS - 安全控制系统：TL 出现故障时启动此系统。



警告

工厂将燃烧器预设为两段火运行模式，因此需将燃烧器与远程控制装置 TR 连接以启动轻油阀 V2。

如果需要运行单段火模式，无需使用控制装置 TR，但需在接线端子 5 和 6 之间加装一个跳接线。

热断路器校准 17)(图 1 第 7 页)



图 18

此操作系为避免由于失相引起输入电流急剧增大而烧毁电机。

- ▶ 如果电机为星形连接驱动，电压 400 V，指示标位于“MIN”。
- ▶ 如果电机为三角形连接驱动，电压 230V，指示标位于“MAX”。

即使电机在电压 400V 时的额定输入功率超出热继电器的量程，电气保护在任何情况下仍会发挥作用。

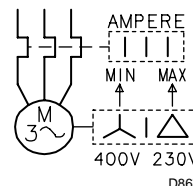
NOTE:

RL 70 - 100 - 130 型燃烧器已由工厂预设为 400 V 电源供给。如果使用 230 V 电源，将电机连接由星形改为三角形，同时改变热继电器的设置。RL 70 - 100 - 130 型燃烧器为间歇式运行。这意味着每隔 24 小时燃烧器将强制停机一次来检测控制器在启动循环中的有效性。正常情况下，锅炉负荷控制系统会将燃烧器自动停机。

若以上情形没有发生，则有必要安装时间继电器，使得每 24 小时至少有一次让燃烧器停机。



警告

不得将零线和相线反接。

**7 管路系统**

**7.1 燃油供应**



图 19

**双管路系统 (图 19)**

燃烧器必须配置一台自吸泵，自吸泵的高度见右表。

**高位油箱 A**

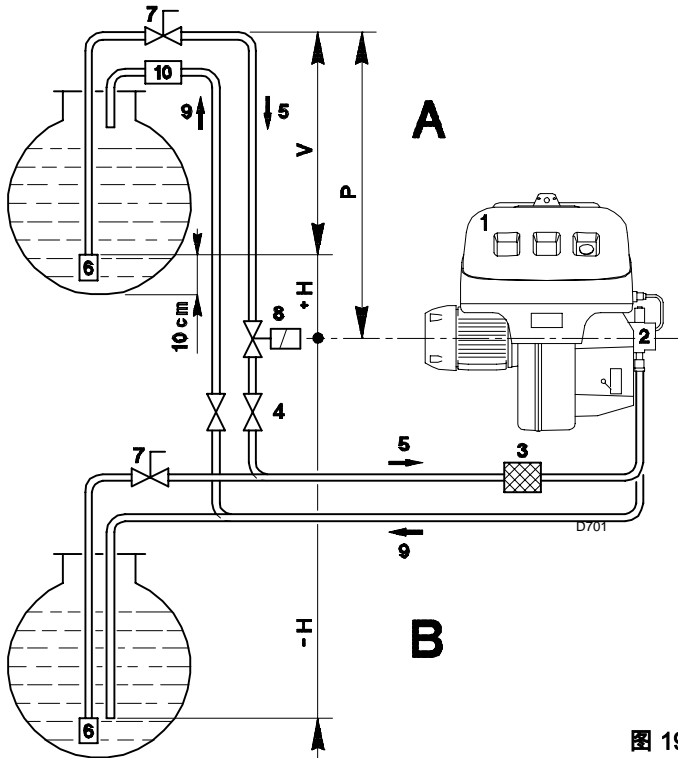
为了避免破坏油箱密封，高度“P”不能超过 10 米；为了油泵在油箱油量极少的情況下依然能吸到油，高度“V”不能超过 4 米。

**低位油箱 B**

油泵吸入口真空度不能超过 0.45 bar (35 cm Hg)，真空度过高会造成燃油汽化，油泵启动噪音大，且会降低油泵寿命。

最好是保持燃烧器进油管和回油管在相同水平高度，这样可以避免进油管吸不到油。

**循环回路**

循环回路是一个闭合管路，燃油在循环油泵作用下从油箱抽出，再回到油箱，包括一个正常压力下运行的辅助泵。从此闭合管路中引出一根支管来为燃烧器供油。这一循环回路在以下情况下特别有用，即当油箱距离太远或高度差大于表中所列数据时，燃烧器不能自动注油启动。

+ H - H (m)	L (m)					
	RL 70 Ø (mm)			RL 100 - 130 Ø (mm)		
	10	12	14	12	14	16
+ 4.0	51	112	150	71	138	150
+ 3.0	45	99	150	62	122	150
+ 2.0	39	86	150	53	106	150
+ 1.0	32	73	144	44	90	150
+ 0.5	29	66	132	40	82	150
0	26	60	120	36	74	137
- 0.5	23	54	108	32	66	123
- 1.0	20	47	96	28	58	109
- 2.0	13	34	71	19	42	81
- 3.0	7	21	46	10	26	53
- 4.0	-	8	21	-	10	25

表 C

**图示说明**

- H = 油泵 / 底阀高度差
- L = 油管长度
- Ø = 油管内径
- 1 = 燃烧器
- 2 = 油泵
- 3 = 过滤器
- 4 = 手动阀
- 5 = 进油管
- 6 = 底阀
- 7 = 快关手动阀 - 远程控制 (仅限意大利)
- 8 = 开 / 关 电磁阀 (仅限意大利)
- 9 = 回油管
- 10 = 单向阀 (仅限意大利)

7.2 油路连接 (图 20)

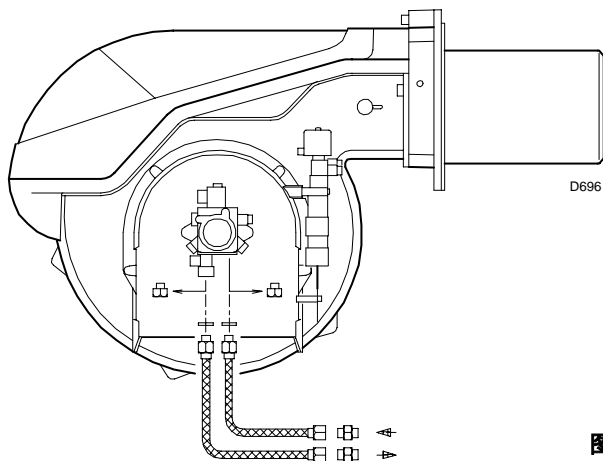

油泵配有旁路系统可以连接进油管 and 回油管。油泵安装在燃烧器上时，旁路系统被螺栓 6) (图 27 第 22 页) 封住了。

需要连接两根软管到油泵上。

如回油管关闭且安装了旁路螺栓，运行油泵将导致油泵立即损坏。

拆下油泵入口和回油口的堵头。

将所附的密封垫加入到连接管连接到油泵并拧紧。

注意安装软管时不要拉伸或扭曲软管。

软管应安装在不易被绊倒的位置，不能接触到锅炉的高温表面。

现在可以安装剩余零件，使用两个扳手，其一固定凸出部，另一个转动软管上的螺扣。

图 20

RL 70  
泵 SUNTEC AL 95 C

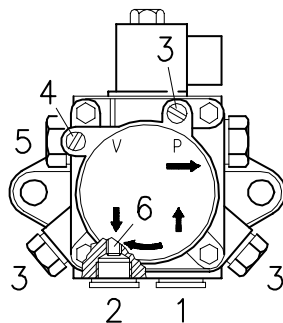

RL 100 - RL 130  
泵 SUNTEC AJ6 CC



图 21

7.3 油泵 (图 21)

- 1 - 供油 G 1/4"
- 2 - 回油 G 1/4"
- 3 - 压力表座 G 1/8"
- 4 - 真空表座 G 1/8"
- 5 - 压力调节螺栓
- 6 - 旁路螺栓
- A - 压力位 12 bar 时的最小输油量
- B - 压力范围
- C - 吸入口最大真空度
- D - 粘度范围
- E - 轻油最高温度
- F - 最大吸入和回油压力
- G - 工厂预设压力
- H - 滤网目宽度

启动所需时间取决于进油管直径和长度。如果首次启动油泵失败且燃烧器锁定，等待大约 15 秒后，复位燃烧器，之后按规定的启动间隔再次启动燃烧器。启动 5 或 6 次后请间隔 2 或 3 分钟，以利于变压器冷却。

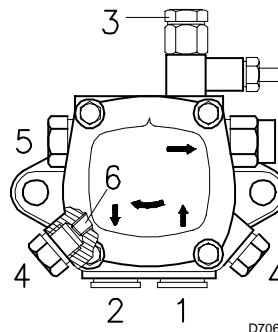
请勿漏光于光电管否则燃烧器将被锁定；燃烧器将在启动 10 秒后锁定。



警告

油泵在出厂时已经注满油。如果有油泄出，请从油泵的真空表座处将油注满，否则会损坏油泵。

当供油管的长度超过 20-30 米，请另加一台独立的油泵。

7.3.1 油泵启动

- 启动燃烧器前，确保油箱回油管路畅通。回油管路堵塞可能损坏油泵轴上的密封圈。(油泵出厂时旁路系统已被堵塞)。
- 启动时，松开油泵上的螺栓 3) (图 21)，排出进油管路中的空气。
- 通过闭合控制装置并将开关 1) (图 20 第 22 页) 置于“ON”位置后，启动燃烧器。油泵转动方向必须与燃烧器外壳上所标箭头方向一致。
- 若从螺栓 3) 处有油漏出，则油泵注油成功。关闭燃烧器，将开关 1) (图 22 第 20 页) 置于“OFF”位置并拧紧螺栓 3)。

8 燃烧器校准

8.1 点火



图 22



警告

检查燃烧器的自我调整、控制和安全设备是否工作正常。

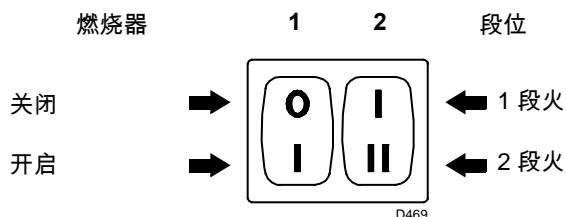
将开关 1) (图 22) 置于“ON”处。

首次点火时，当一段火运行转换为二段火运行时，会因燃油需将二段火喷嘴管路注满而出现短暂的油压下降现象。这一压力的下降可能会导致燃烧器锁定，有时还会引起燃烧器震动。

首次启动安全提示



警告

燃烧器首次启动必须由取得资质的人员进行操作，并符合手册所述、现行的标准和法规。

如果能进行如下调整，燃烧器点火时的噪音就会接近其运行时的噪音。如果燃烧器在开启轻油电磁阀时出现一两次震动或延迟点火现象，请查看 27 页上第 34 - 42 项原因。

8.2 运行



图 23



图 24

**14 bar:** 为了增大喷油量或确保环境温度低于 0°C 时的点火启动。调整油泵压力，可使用螺栓 5) (图 19 第 21 页)。

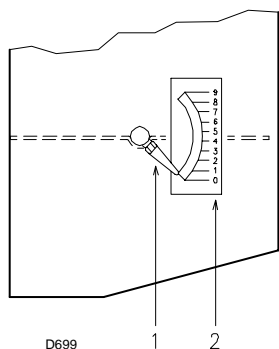
► 一段火风机风量挡板

将开关 2) (图 22) 置于一段火运行处以保持燃烧器在一段火时的平稳运行。风量挡板 6) (图 24) 的开启程度必须根据所选喷嘴进行调整；指针 1) (图 23) 必须与标有刻度的扇型刻度盘 7) (图 23) 相应位置对齐。可以用六角螺丝进行调整 2) (图 24)：

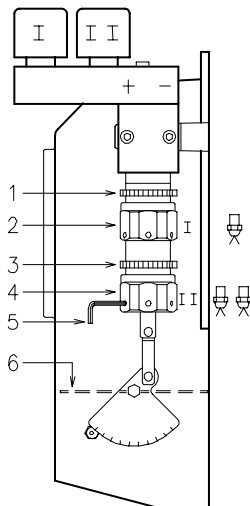
- 向右旋 (- 号方向) 减少进风量；
- 向左旋 (+ 号方向) 增大进风量。

**举例：**RL 70 - 一段火喷嘴 6.0 GPH：

刻度 2.3 (图 23) 必须与指针 1) 对齐。

调整结束后，用螺母 1) 将六角螺丝 2) (图 24) 拧紧。

RL 70		RL 100		RL 130	
GPH	N°	GPH	N°	GPH	N°
5	2.0	7	2.0	10	2.0
6	2.3	8	2.1	11	2.1
7	2.6	9	2.2	12	2.2
8	2.7	10	2.4	13	2.3
9	2.8	11	2.6	14	2.5
		12	2.7	15	2.6
		13	2.8	16	2.7
		14	2.9	17	2.8
				18	2.9
				19	3.0

表 D

N° = 刻度 2) (图 23)

燃烧器的优化校准需要在锅炉排烟口安装烟气分析仪，并对以下部分进行调整：

► 1 号和 2 号喷嘴

内容详见第 12 页

► 燃烧头

除非改变二段火时燃烧器的喷油量，否则燃烧头已完成的调整不需要改变。

► 油泵压力

**12 bar:** 此压力为出厂时的预设值，可以满足大部分用户的需求。有些情况下，也需对此压力作出调整，如：

**10 bar:** 为了减少喷油量。只有在环境温度高于 0°C 时，才能作此调整。但绝对不可调至低于 10 bar，否则液压缸将难以开启；

► 二段火风机风量挡板

将开关 2) (图 22 第 20 页) 置于二段火运行位置, 松开螺母 3) (图 24) 后, 转动六角螺丝 4) (图 24) 调整风量挡板 6) (图 24)。

附件 1) (图 25) 的气压值必须接近表 (图 25) 所示压力与附件 2) 所测炉膛压力之和。参考图中所示。

RL 70		RL 100		RL 130	
kg/h	mbar	kg/h	mbar	kg/h	mbar
40	8.5	60	7.2	80	7
50	8.6	70	7.7	90	7.2
60	8.8	80	8.4	100	7.6
70	9.2	90	9.3	110	8.1
		100	11.0	120	9.0
				130	11.0
				130	8.5 <sup>(1)</sup>

表 E

mbar = 在测点 2) 压力为零时测点 1) 处的风压

(1) 风量挡板 4) 关闭 (图 8 页 11)

NOTE:

为了方便地调整六角螺丝 2) 和 4) (图 24), 可使用 3 mm 六角扳手 5) (图 24)。



图 25



D3280

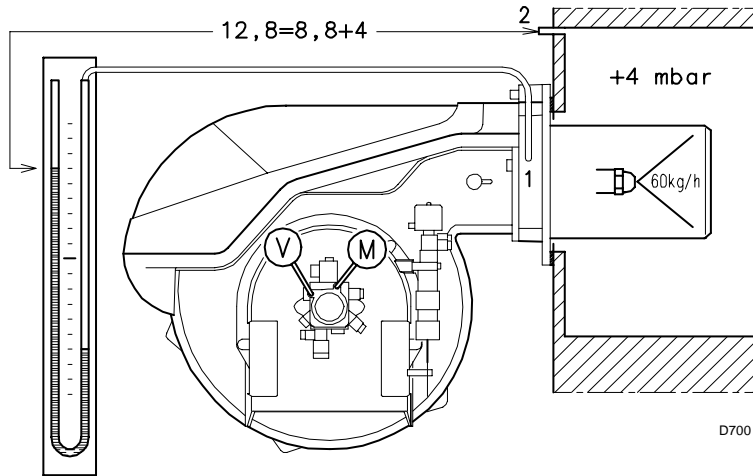
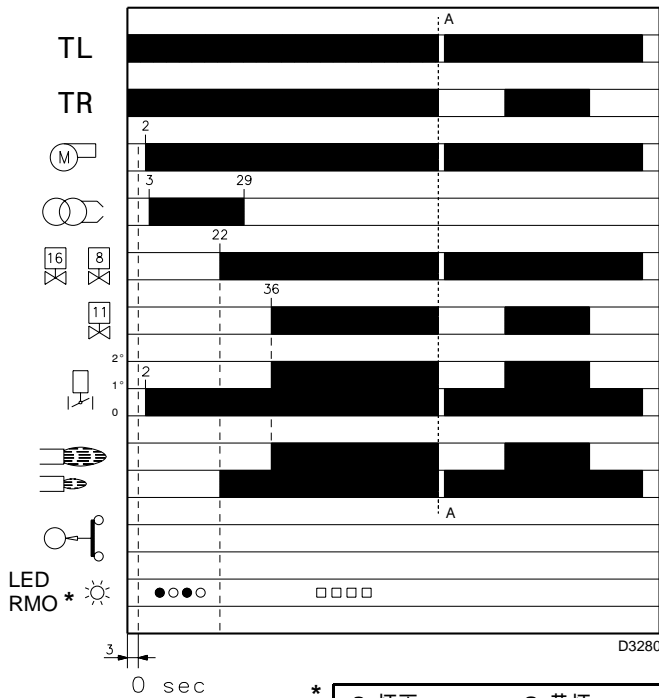
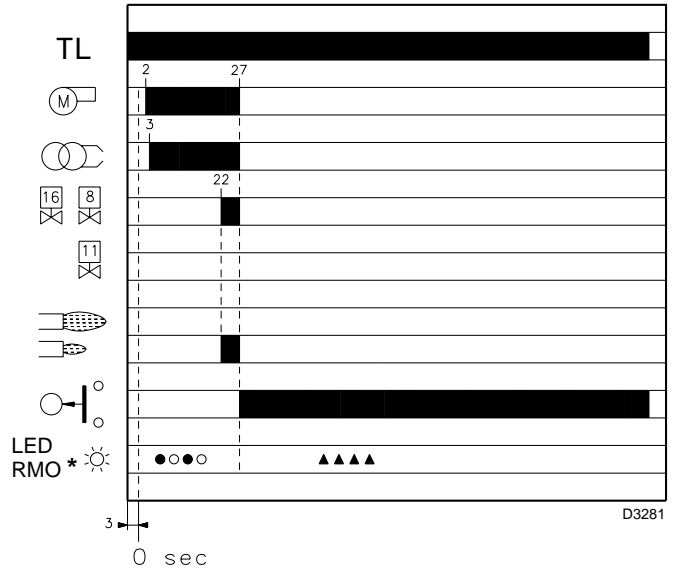

D3281

\* ○ 灯灭      ● 黄灯      □ 绿灯      ▲ 红灯  
 详见第 26 页

图 26

## 8.2.1 燃烧器启动 (图 26) - (图 27)



图 27

启动阶段各步骤的时间间隔以秒计，显示如下：

控制装置 TL 闭合。

大约 3 秒后：

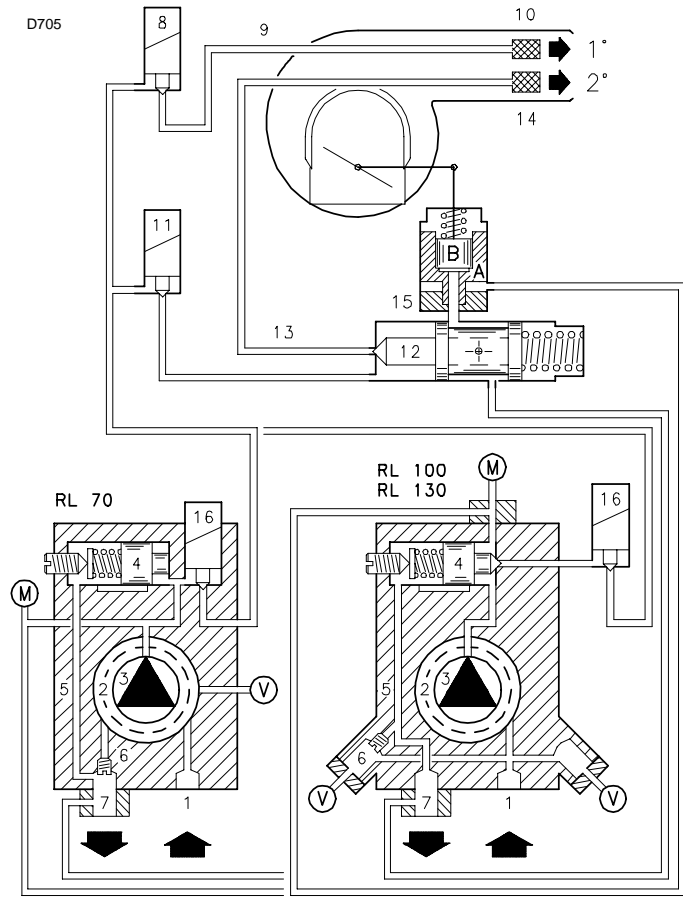
- **0 秒**：控制盒启动阶段开始。
- **2 秒**：风机电机开始启动。
- **3 秒**：点火变压器通电。  
油泵 (3) 通过油管 (1) 及滤油器 (2) 将燃油吸入泵中，并开始加压送油。活塞 (4) 升高，燃油通过油管 (5) - (7) 流回油箱。螺栓 (6) 将泵内旁路关闭，电磁阀 (8) - (11) - (16) 断电，关闭油路。  
液压缸 (15) 及活塞 A 开启风量挡板：一段火开始送风进行预吹扫。
- **22 秒**：电磁阀 (8) 和 (16) 开启，燃油流经油管 (9) 和滤油器 (10)，由喷嘴喷出，遇点火电极产生的火花后点燃。此为一段火火焰。
- **29 秒**：点火变压器断开。
- **36 s: 36 秒**：如果控制装置 TR 未开启或被替换，二段火电磁阀 (11) 打开，燃油进入控制阀 (12) 并抬升活塞，同时打开两个油路：一路流向油管 (13)，滤油器 (14) 及二段火喷嘴，另一路流向液压缸 (15) 和活塞 B，开启二段火风量挡板。至此，启动周期结束。

## 8.2.2 稳态运行

## 装有控制装置 TR 的系统

启动周期结束后，控制装置 TR 传递指令给二段火电磁阀来控制锅炉温度与压力。

- 如果温度或压力升高至控制装置 TR 断开，则电磁阀 (11) 关闭，燃烧器由二段火转为一段火运行。
- 如果温度或压力降低至控制装置 TR 闭合，则电磁阀 (11) 开启，燃烧器由一段火转为二段火运行。以此类推。
- 一段火运行时，如热量需求小于燃烧器所输送的热量时，燃烧器停止运行。在此情况下，远程控制装置 TL 断开，电磁阀 (8) - (16) 关闭，火焰立即熄灭。风机风量挡板完全关闭。

## 未装控制装置 TR 的系统 (装有短接线)

燃烧器会按以上所述点燃。如果温度或压力升高至控制装置 TL 开启，则燃烧器停机 (如图 A-A 所示)。

当电磁阀 (11) 断电，活塞 (12) 关闭二段火喷嘴油路，液压缸 (15) 及活塞 B 内燃油流入回油管 (7)。

## 8.2.3 点火失败

如果燃烧器点火失败，会在 1 号喷嘴开启 5 秒之内或在控制装置 TL 闭合 30 秒后进入锁定状态。

控制盒红色指示灯将会亮起。

## 8.2.4 燃烧器运行中意外停机

如果运行过程中火焰熄灭，燃烧器将会在 1 秒内自动停机，并且会自动进入启动阶段启动。

## 8.2.5 最终检查

- **闭合控制装置及遮蔽光电管**：燃烧器将启动，并在开启 1 号喷嘴 5 秒后锁定。
- **闭合控制装置并让光电管感光**：燃烧器将启动，并在大约 10 秒后锁定。
- **燃烧器处于二段火运行时，拔出光电管，会接连出现以下情况**：火焰 1 秒内熄灭，预吹扫约 20 秒，点火约 5 秒，燃烧器进入锁定状态。
- **燃烧器运行时，顺序断开控制装置 TL 及 TS**：燃烧器将停止运行。

9 维护

安全维护提示

定期的维护有利于燃烧器的良好运行、安全、出力和持续稳定性。有助于减少能耗和污染排放，并使产品长期保持在可靠状态。



危险

燃烧器的维护和校准，必须由取得资质的、经授权的人员根据说明书并遵照标准和现行的法规来进行操作。

在实施维护前，检查操作流程并清洁设备：



危险

在进行任何清洁或操作之前，先切断燃烧器系统主开关的电源；



危险

在进行任何清洁或操作之前，关闭燃料阀门；

燃烧

燃烧器的优化校准需要烟气分析仪。维护时与原有数据存在较大差异的地方应多加注意。

油泵

油泵工作时压力必须稳定在 12 bar。

真空度必须低于 0.45 bar。

油泵工作时不能存在异常声响。

如果压力不稳或者油泵运转噪声过大，必须将从过滤网上卸下软管，并从附近的油箱中为油泵供油。这一措施可以诊断进油管 and 油泵的工作是否异常。

如果油泵工作异常，检查并确保过滤网未被堵塞。真空计安装位置位于过滤网之前，因此不能提示过滤网是否被堵塞。

反之，如果进油管出问题，检查确保过滤网清洁以及进油管内没有空气进入。

过滤网 (图 28)

检查以下过滤网：

- 油路 1) • 油泵 2) • 喷嘴 3)，必要时清洁或更换过滤网。

如果油泵内生锈或有污物，请使用另一台独立的油泵将油箱底部的水或污物抽出。



图 28

风机

检查确保风机内部或叶轮上没有灰尘积聚，灰尘会减少进风量并增加燃烧污染物的排放。

燃烧头

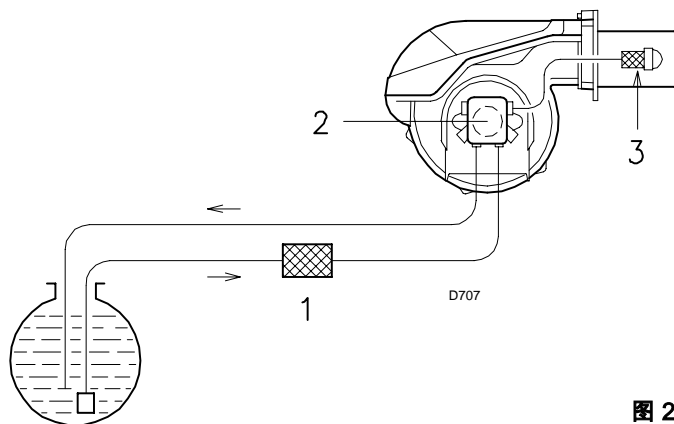
检查确保燃烧头的所有部件性能完好、安装正确以及未被污染，这样燃烧器就不会再高温运行时出现故障。

喷嘴

不要清洁喷嘴口；最好不要打开喷嘴口。

建议每 2-3 年或根据需要进行更换喷嘴。更换后务必检查燃烧状况。

光电管 (图 29)

清洁玻璃罩上可能积聚的灰尘。安装或取下光电管 1) 时都需用力。



图 29



**火焰观察孔 (图 30)**

必要时，清洁观察孔处的玻璃。

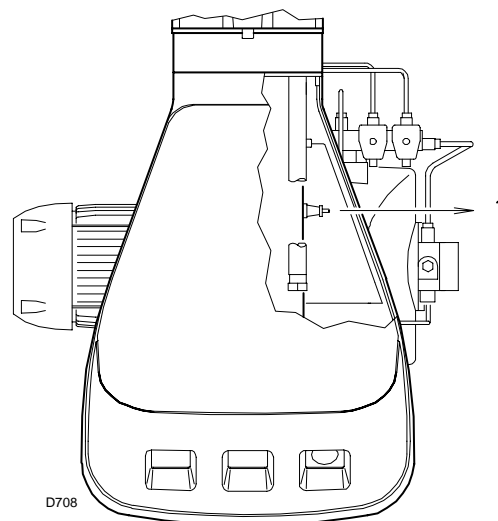
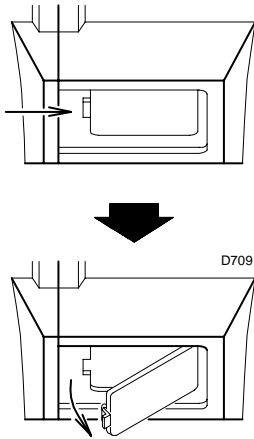

**图 30**

**燃料泵和 / 或管路接口更换 (图 32)**

按照 (图 32) 说明进行操作

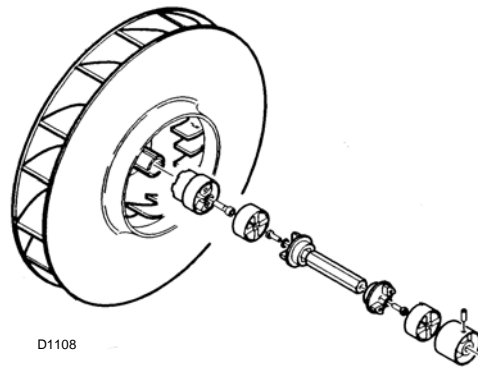

**图 32**

**软管**

检查确保软管状况良好，未遭损坏或变形。

**油箱**

大约每 5 年或有必要时，燃料箱底部进水或有污物时，需要启用另一台独立的油泵清洁油箱。

**锅炉**

为了保持最初的燃烧性能不被破坏，请按随附说明书上的要求清洁锅炉，特别要注意烟气温度和炉膛压力。

**打开燃烧器 (图 31)**

断开电源。

松开螺丝 1)，取下保护罩 2)。

卸下螺栓 3)。

将燃烧器随附的两个加长部件 4) 装到滑杆 5) 上 (针对 385 mm 长的燃烧筒)。

略抬起机体 A 并向后拉，注意不要碰坏在燃烧筒 7) 里的稳焰盘 6)。

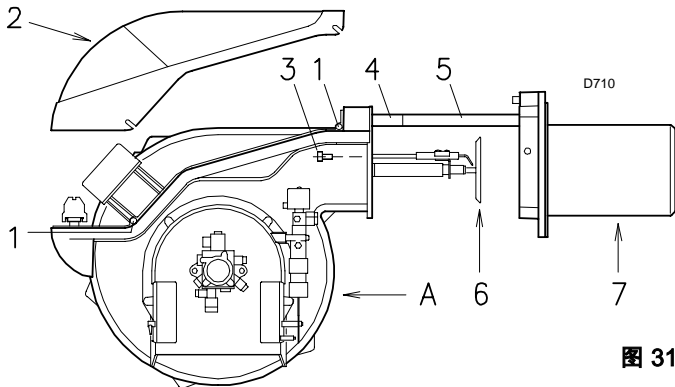

**图 31**



### 9.1 燃烧器启动阶段故障诊断

启动过程中指示灯指示见下表：

颜色代码表	颜色代码
启动过程	颜色代码
预吹扫	● ○ ● ○ ● ○ ● ○ ●
点火阶段	● ○ ● ○ ● ○ ● ○ ●
运行，火焰正常	□ □ □ □ □ □ □ □ □
运行，火焰较弱	□ ○ □ ○ □ ○ □ ○ □
电压低于 ~ 170V	● ▲ ● ▲ ● ▲ ● ▲ ●
锁定	▲ ▲ ▲ ▲ ▲ ▲ ▲ ▲ ▲
外部光源	▲ □ ▲ □ ▲ □ ▲ □ ▲
图例：	○ 灯灭      ● 黄灯      □ 绿灯      ▲ 红灯

### 9.2 复位控制盒及执行故障诊断

控制盒具有故障诊断功能，因此能很容易确定故障原因（指示器：红色 LED 指示灯）。  
 要使用这一功能，须等进入安全保护状态（锁定状态）至少 10 秒之后再按下复位按钮。  
 控制盒发出一组脉冲信号（相隔 1 秒），该组信号会以 3 秒间隔不断重复出现。  
 可根据指示灯的闪烁次数来判断可能的故障原因，系统复位时必须按住按钮 1-3 秒。



以下方法可用来复位控制盒及执行故障诊断。

### 9.3 复位控制盒

- 复位控制盒程序如下：
- 按住复位键 1-3 秒；
  - 松开复位键 2 秒后燃烧器重启。
- 如果温度限位开关处于断开状态，则燃烧器不能重启。

### 9.4 可视诊断

- 提示引起燃烧器锁定的故障类型。
- 查看故障诊断，并按以下步骤操作：
- 当红色 LED 持续亮起（燃烧器锁定）时，按住按钮超过 3 秒。
- 黄灯闪烁说明操作成功。  
 指示灯闪烁则松开按钮。指示灯闪烁次数提示故障原因，如第 27 页列表所示。

## 9.5 软件诊断

通过与 PC 电脑连接，报告燃烧器使用寿命，提示运行时间、锁定次数及类型、控制盒序列号等。

查看故障诊断，并按以下步骤操作：

— 当红色 LED 持续亮起（燃烧器锁定）时，按住按钮超过 3 秒。

黄灯闪烁说明操作成功。

松开按钮 1 秒后再次按下按钮超过 3 秒直至黄灯再次闪烁。

松开按钮，红色 LED 高频闪烁；此时红外端口被激活。

一旦操作成功，必须按照上述控制盒复位程序将控制盒恢复至初始状态。

按键时间	控制盒状态
1-3 秒	在可视诊断前复位控制盒。
大于 3 秒	在锁定状态进行可视诊断： (LED 指示灯以 1 秒间隔闪烁)。
开始可视诊断后超过 3 秒	通过红外线与 PC 电脑连接进行软件诊断 (可查看运行时间、故障等)。

控制盒指示灯闪烁情况提示故障类型，如第 27 页列表所示。

指示灯	故障	可能的故障原因	排除故障建议
不闪烁	燃烧器未启动	1 - 电源未供电 2 - 限位控制装置 TL 开启 3 - 安全控制装置 TS 开启 4 - 控制盒锁定 5 - 油泵堵塞 6 - 不正确的电气接线 7 - 控制盒损坏 8 - 电机损坏	闭合所有开关 - 检查保险丝 调节或更换 调节或更换 复位控制盒 (锁定 10 秒后) 更换 检查接线 更换 更换
闪烁 2 次 ● ●	预吹扫及安全时间过后， 燃烧器进入锁定状态	9 - 油箱中没有油；油箱底部有水 10 - 燃烧头及风量挡板调节不当 11 - 燃油电磁阀打开失败 (一段火或安全阀) 12 - 1 段火喷嘴堵塞、脏或损坏 13 - 点火电极脏或调节不当 14 - 由于绝缘破损电极接地 15 - 高压电缆损坏或接地 16 - 高压电缆由于高温而损坏 17 - 点火变压器损坏 18 - 电磁阀或点火变压器电气连接错误 19 - 控制盒损坏 20 - 油泵不启动 21 - 油泵 / 电机联轴器断开 22 - 油泵吸油管和回油管短路 23 - 油泵上游的阀关闭 24 - 过滤网脏：油路 - 油泵 - 喷嘴 25 - 光电管或控制盒损坏 26 - 光电管脏 27 - 一段火运行液压缸故障 28 - 电机锁定 29 - 电机启动远程控制失败 30 - 二段火供电热继电器失效 31 - 电机转向错误	增加油到相应水平或抽走油箱底部水 调节，见 14 页及 20 页 检查连接或更换线圈 更换 调整或清洁 更换 更换 更换并采取保护措施 更换 检查 更换 启动油泵，参见“油泵不启动” 更换 正确连接 开启 清洁 更换光电管或控制盒 清洁 更换液压缸 复位热继电器 更换 接通三相电源，复位热继电器 更改电机电气连接
闪烁 4 次 ● ● ● ●	燃烧器启动之后进入锁定 状态	32 - 光电管短路 33 - 有外部光源进入或虚假火焰	更换光电管 消除光源或更换控制盒

指示灯	故障	可能的故障原因	排除故障建议
闪烁 7 次 ● ● ● ● ● ● ●	脱火	34 - 燃烧头调节不当 35 - 点火电极调节不当或脏 36 - 风量挡板调节不当：进风量过大 37 - 1 段火喷嘴喷油量过大（震动） 38 - 1 段火喷嘴喷油量过小（脱火） 39 - 1 段火喷嘴脏或变形 40 - 油泵压力不当 41 - 1 段火喷嘴与燃烧器或锅炉不匹配 42 - 一段火喷嘴损坏	调整，见 14 页，图 14 调整，见 14 页，图 10 或清洁 调整 减小 1 段火喷嘴喷油量 增大 1 段火喷嘴喷油量 更换 调整至 10 - 14 bar 参见喷嘴列表，第 12 页；减小 1 段火喷嘴喷油量 更换
	燃烧器不能运行二段火	43 - 控制装置 TR 不能闭合 44 - 控制盒故障 45 - 二段火电磁阀线圈故障 46 - 活塞堵塞	调整或更换 更换 更换 整体更换
	燃油进入二段火运行但进风量仍为一段火进风量	47 - 油泵压力低 48 - 二段火风量挡板液压缸故障	加压 更换液压缸
	一、二段火转换时燃烧器停机。燃烧器重复启动周期。	49 - 油嘴脏 50 - 光电管脏 51 - 进风量过大	更换 清洁 减小进风量
	燃油供应不稳定	52 - 检查原因是否出在油泵或燃油供应系统	从就近的油箱为燃烧器供油
	油泵内部生锈	53 - 油箱内有水	用另一个泵将油箱内水抽干
	油泵噪音大，泵压不稳	54 - 进油管内有空气 - 油泵进油压力过高（高于 35 cm Hg） 55 - 油箱 / 燃烧器 高度落差太大 56 - 管道直径太小 57 - 进油管过滤网堵塞 58 - 进油阀关闭 59 - 温度过低，燃油凝固	紧固接头 采用循环回路为燃烧器供油 增大 清洁 开启 向燃油中加入添加剂
	油泵长时间不启动	60 - 回油管没有燃油 61 - 进油管有空气	升高至与进油管同样高度 紧固接头
	油泵漏油	62 - 从密封圈处泄漏	更换油泵
	烟气 - 黑度等级  - 黄度等级	63 - 空气不足 64 - 喷嘴磨损或脏 65 - 喷嘴过滤网堵塞 66 - 油泵压力不当 67 - 稳焰盘脏、松动或变形 68 - 炉膛通风不足 69 - 进风量过大	调整燃烧头和风量挡板，见第 14 页和第 20 页 更换 清洁或更换 调整至 10 - 14 bar 清洁、紧固或更换 增大 调节燃烧头和风量挡板，见第 14 页和第 20 页
	燃烧头脏	70 - 喷嘴或过滤网脏 71 - 喷嘴喷油量或角度不当 72 - 喷嘴松动 73 - 稳焰盘上有杂物 74 - 燃烧头调节不当或进风量不足 75 - 燃烧筒长度与锅炉不匹配	更换 参见推荐喷嘴，第 12 页 紧固 清洁 调整，见第 20 页；打开风门挡板 联系锅炉制造商
闪烁 10 次 ● ● ● ● ● ● ● ● ● ●	燃烧器锁定	76 - 接线错误或内部故障 77 - 存在电磁干扰	使用抗电磁干扰保护配件

## 10 状态显示面板 ( 可选 )

根据需要订购的配件 见第 6 页

### 10.1 组装

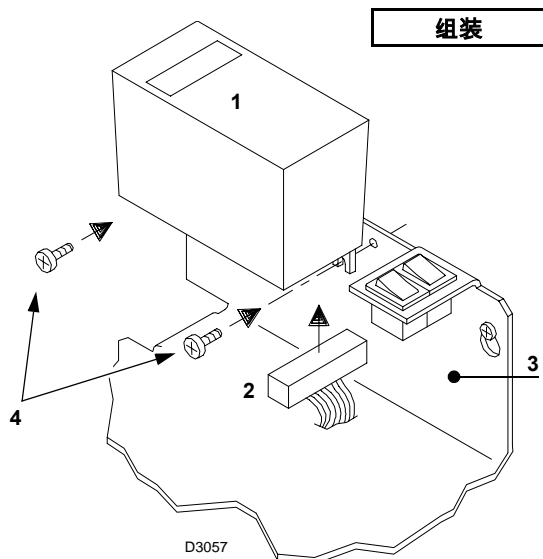

燃烧器已为安装“状态显示面板”预留了位置，安装步骤如下：

- 用连接线 2) 将“状态显示面板” 1) 安装到支架 3) 上。
- 使用随此组件附带的螺栓 4) 将“状态显示面板” 固定在支架上。

- 1 状态显示面板
- 2 连接器
- 3 燃烧器支架
- 4 安装螺栓

图 33

### 10.2 “状态显示面板”具有以下三个功能：

**1 读数面板 V 可显示燃烧器运行小时数和点火次数。**

**总的运行小时数**

按按钮 "h1".

**2 段火运行小时数**

按按钮 "h2".

**1 段火运行小时数 ( 计算 )**

总小时数 - 2 段火运行小时数

**点火次数**

按按钮 "count".

**复位运行小时数和点火次数**

同时按下三个“reset”键

**运行稳定状态记录**

即使出现断电情况，运行小时数和点火次数仍会储存在面板内。

2 显示和点火各阶段有关的次数

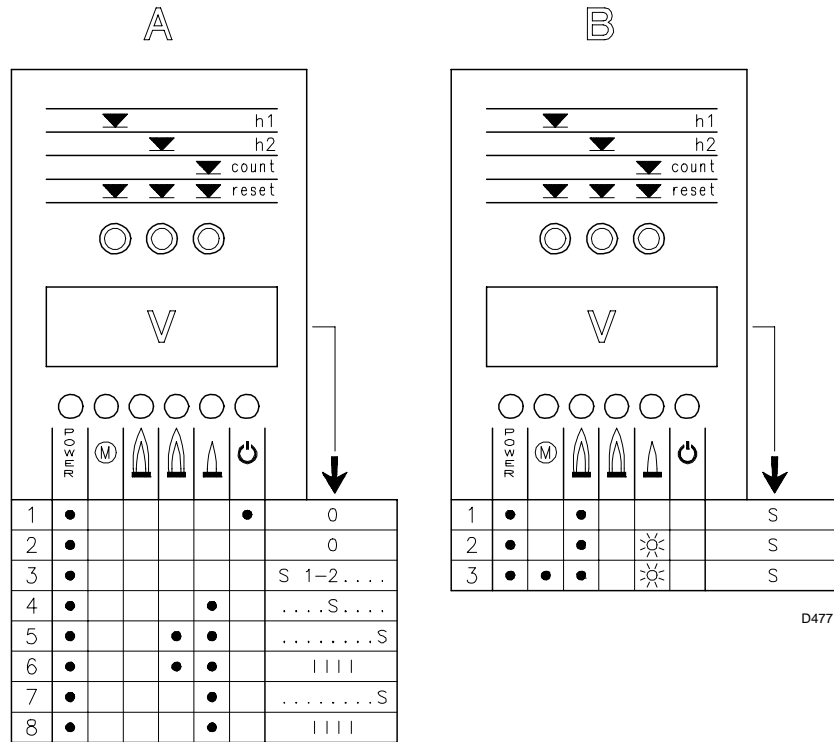

D477

- ☼ = LED 闪烁
- = LED 灯亮
- S = 按秒计时
- |||| = 燃烧器启动周期结束

图 34

led 指示灯以下列顺序亮起，见图 A：

控制装置 TR 关闭：

- 1- 燃烧器停机，TL 开启
- 2- 控制装置 TL 关闭
- 3- 电机启动：  
读数面板 V 开始计秒
- 4- 1 段火阀通电
- 5- 2 段火阀通电  
读数面板 V 停止计秒
- 6- 第 5 阶段后 10 秒，代码 |||| 将出现在读数面板上：这显示启动周期结束。

控制装置 TR 开启：

- 1- 燃烧器停机，TL 开启
- 2- 控制装置 TL 关闭
- 3- 电机启动：  
读数面板 V 开始计秒
- 4- 1 段火阀通电
- 7- 第 4 阶段后 30 秒：  
读数面板 V 停止计秒
- 8- 第 7 阶段后 10 秒，代码 |||| 将出现在读数面板上：这显示启动周期结束。

读数面板 V 上显示的次数、秒数可指示第 22 页上所述之启动周期中不同阶段的次序。

3 如果燃烧器出现故障，“状态显示面板”会显示故障发生的确切时间。

led 灯亮起，有三种可能性，见图 B。

故障原因可查阅括号中的数字：数字含义见第 27 页上图例。

- 1..... (9 ÷ 10)
- 2..... (11 ÷ 33)
- 3..... (32)

指示信号 ( 状态面板 )

- **POWER** = 电源显示
- (M) = 风机电机锁定 ( 红色 )
- (燃烧器图标) = 燃烧器锁定 ( 红色 )
- (2段火图标) = 2 段火运行
- (1段火图标) = 1 段火运行
- (电源按钮图标) = 达到负荷要求 ( 待机 )，led 灯亮

D478





---

# RIELLO

Registered Office - 公司注册所在地 :  
RIELLO S.p.A.  
I-37045 Legnago (VR)  
Tel.: +39.0442.630111  
[http:// www.riello.it](http://www.riello.it)  
[http:// www.rielloburners.com](http://www.rielloburners.com)

Manufacturing site:  
Riello Heating Equipment (Shanghai) CO., LTD  
No. 388, Jinbai Road - Jinshan Industrial Zone  
201506 - Shanghai  
CHINA

生产场所 :  
Riello Heating Equipment (Shanghai) CO., LTD  
利雅路热能设备 (上海) 有限公司  
上海市金山工业区金百路 388 号